

# Precision tools for CNC machines



**BUP**<sup>®</sup>  
U T E N S I L I

[www.buputensili.it](http://www.buputensili.it)

5



A/07



**5**



**CNC insert  
router cutters**



**APPLICATION:**

Production of MDF kitchen doors or decoration of MDF panels.

**MACHINE:**

CNC router.

**TECHNICAL INFORMATION:**

Manufactured with indexable micrograin solid carbide knives. On request we can produce for solid wood with suitable cutting angles. Supplied with cylindrical shank d. 20x50. Increase of 15% for tapered shanks.

**MEC HW**

Code	D	S	Z	Rpm Max	Price Code	Profile	Spare Parts		
							Knife	Screw	Key
5001.000.001	65	40	2	16.000	L23	A	8170.040.035	8330.035.003	8345.015.000
5001.000.002	50	25	2	18.000	D22	B	8170.030.025	8330.035.003	8345.015.000
5001.000.003	24	25	1	20.000	B19	C	8170.025.012	8330.035.003	8345.015.000
5001.000.004	24	25	1	20.000	B19	D	8170.025.012	8330.035.003	8345.015.000

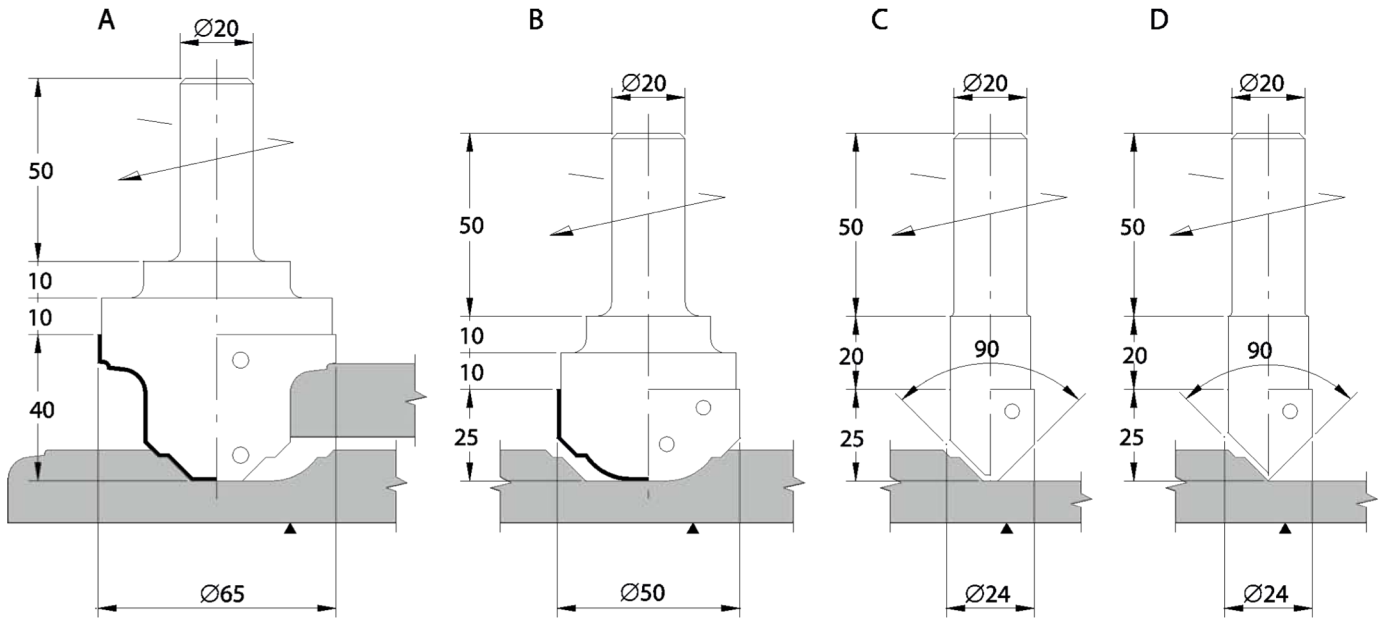

SECTION:

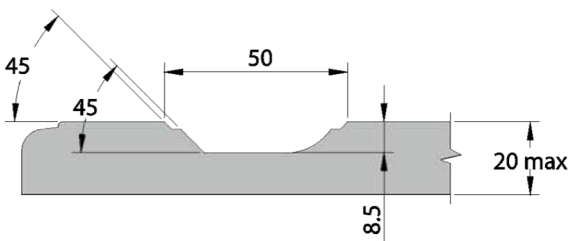

VIEW:

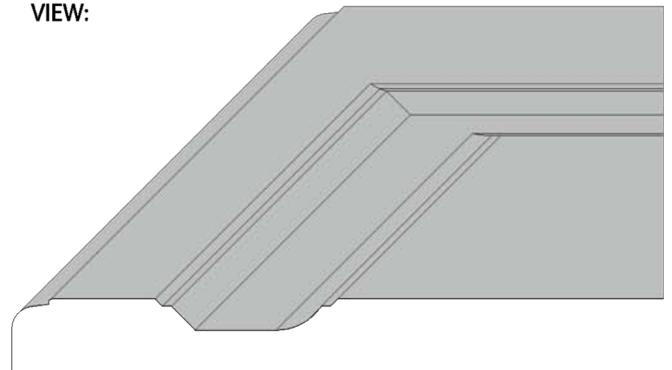



**APPLICATION:**

Production of MDF kitchen doors or decoration of MDF panels.

**MACHINE:**

CNC router.

**TECHNICAL INFORMATION:**

Manufactured with indexable micrograin solid carbide knives. On request we can produce for solid wood with suitable cutting angles. Supplied with cylindrical shank d. 20x50. Increase of 15% for tapered shanks.

**MEC HW**

Code	D	S	Z	Rpm Max	Price Code	Profile	Spare Parts		
							Knife	Screw	Key
5002.000.001	60	35	2	16.000	B23	A	8170.035.035	8330.035.003	8345.015.000
5002.000.002	30	20	2	20.000	C21	B	8170.015.020	8330.035.003	8345.015.000
5002.000.003	24	25	1	20.000	G19	C	8170.025.012	8330.035.003	8345.015.000
5002.000.004	24	20	1	20.000	F19	D	8170.020.012	8330.035.003	8345.015.000

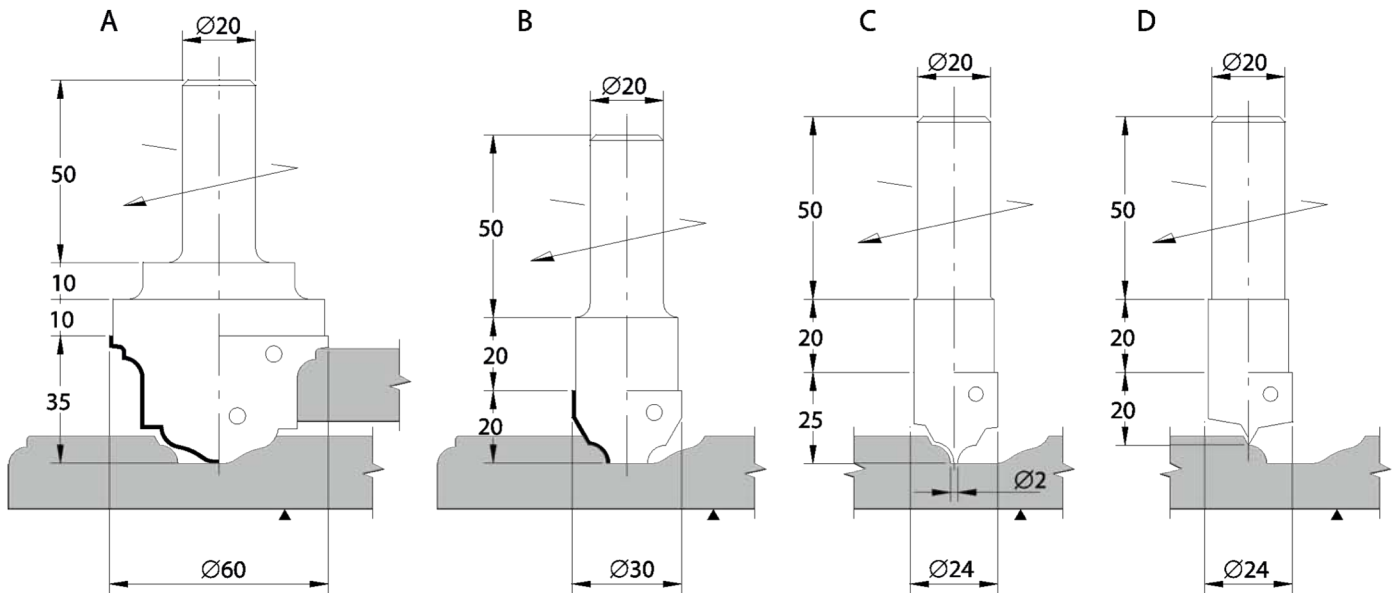

SECTION:

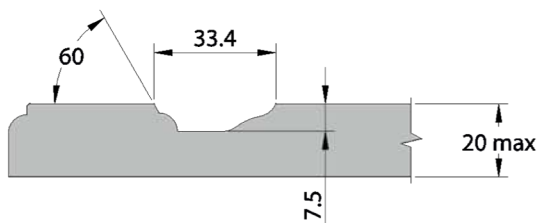

VIEW:

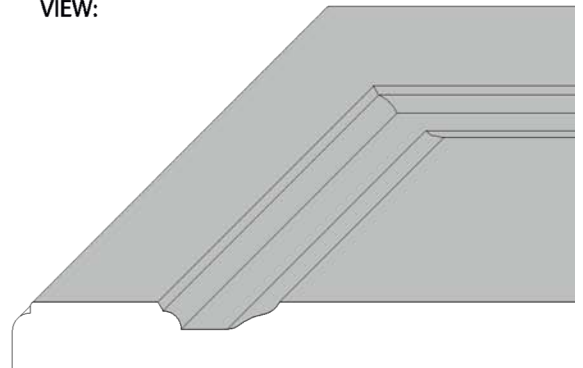



**APPLICATION:**

Production of MDF kitchen doors or decoration of MDF panels.

**MACHINE:**

CNC router.

**TECHNICAL INFORMATION:**

Manufactured with indexable micrograin solid carbide knives. On request we can produce for solid wood with suitable cutting angles. Supplied with cylindrical shank d. 20x50. Increase of 15% for tapered shanks.

**MEC HW**

Code	D	S	Z	Rpm Max	Price Code	Profile	Spare Parts		
							Knife	Screw	Key
5003.000.001	50	35	2	18.000	M22	A	8170.035.025	8330.035.003	8345.015.000
5003.000.002	30	25	2	20.000	H21	B	8170.015.025	8330.035.003	8345.015.000

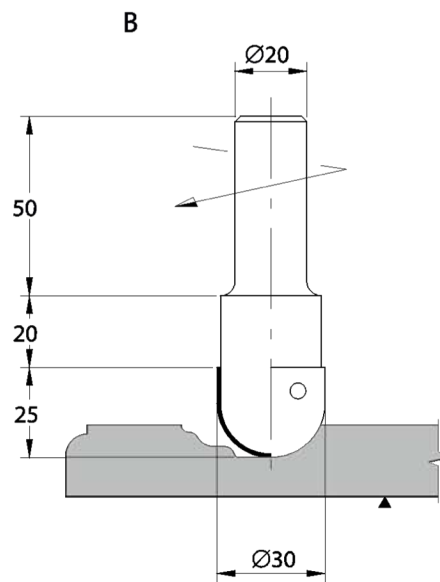
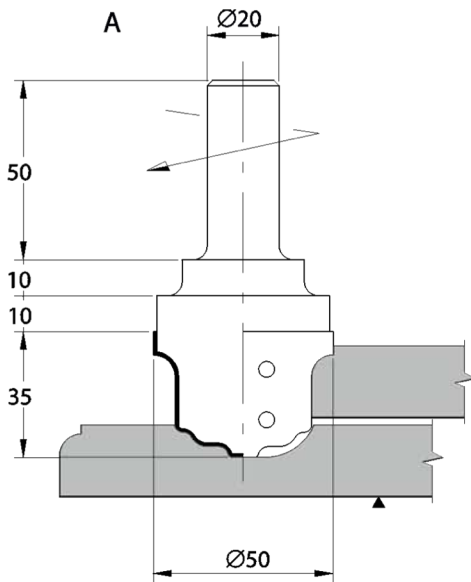

SECTION:

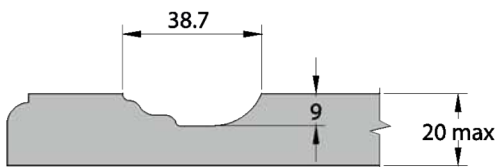

VIEW:

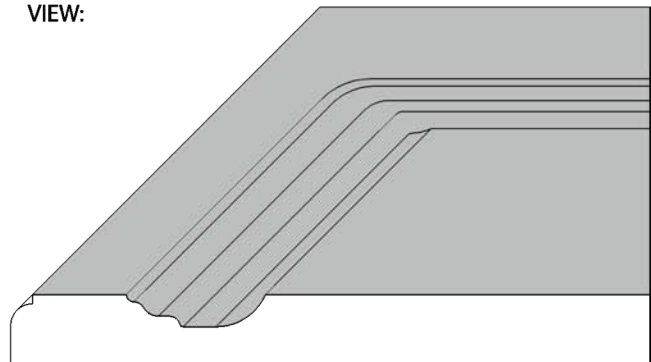



**APPLICATION:**

Production of MDF kitchen doors or decoration of MDF panels.

**MACHINE:**

CNC router.

**TECHNICAL INFORMATION:**

Manufactured with indexable micrograin solid carbide knives. On request we can produce for solid wood with suitable cutting angles. Supplied with cylindrical shank d. 20x50. Increase of 15% for tapered shanks.

**MEC HW**

Code	D	S	Z	Rpm Max	Price Code	Profile	Spare Parts		
							Knife	Screw	Key
5004.000.001	60	30	2	18.000	L22	A	8170.030.030	8330.035.003	8345.015.000
5004.000.002	50	25	2	18.000	D22	B	8170.030.025	8330.035.003	8345.015.000
5004.000.003	40	20	2	20.000	C21	C	8170.020.020	8330.035.003	8345.015.000
5004.000.004	24	20	2	20.000	F20	D	8170.020.012	8330.035.003	8345.015.000

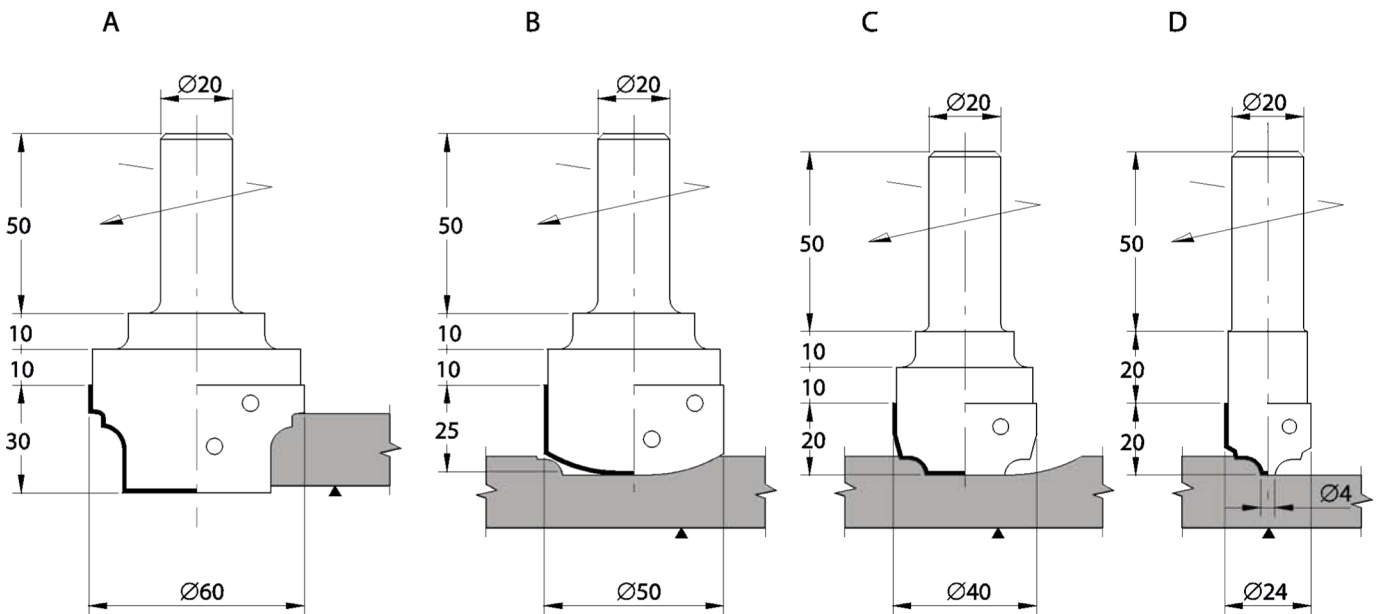

SECTION:

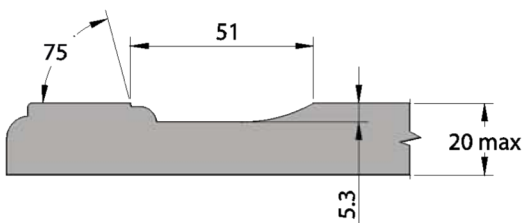

VIEW:

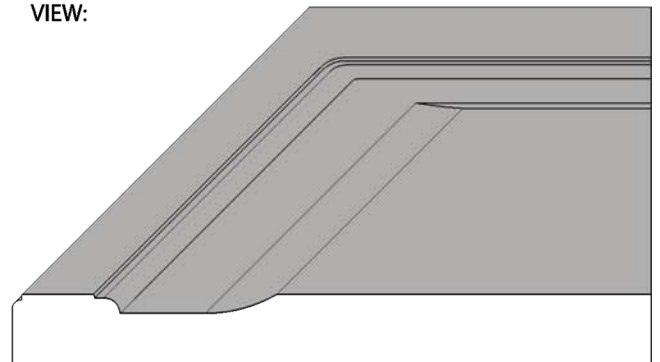



**APPLICATION:**

Production of MDF kitchen doors or decoration of MDF panels.

**MACHINE:**

CNC router.

**TECHNICAL INFORMATION:**

Manufactured with indexable micrograin solid carbide knives. On request we can produce for solid wood with suitable cutting angles. Supplied with cylindrical shank d. 20x50. Increase of 15% for tapered shanks.

**MEC HW**

Code	D	S	Z	Rpm Max	Price Code	Profile	Spare Parts		
							Knife	Screw	Key
5005.000.001	70	35	2	16.000	E24	A	8170.035.035	8330.035.003	8345.015.000
5005.000.002	60	25	2	18.000	H22	B	8170.030.025	8330.035.003	8345.015.000
5005.000.003	30	25	2	20.000	H21	C	8170.015.025	8330.035.003	8345.015.000
5005.000.004	24	20	2	20.000	F20	D	8170.020.012	8330.035.003	8345.015.000

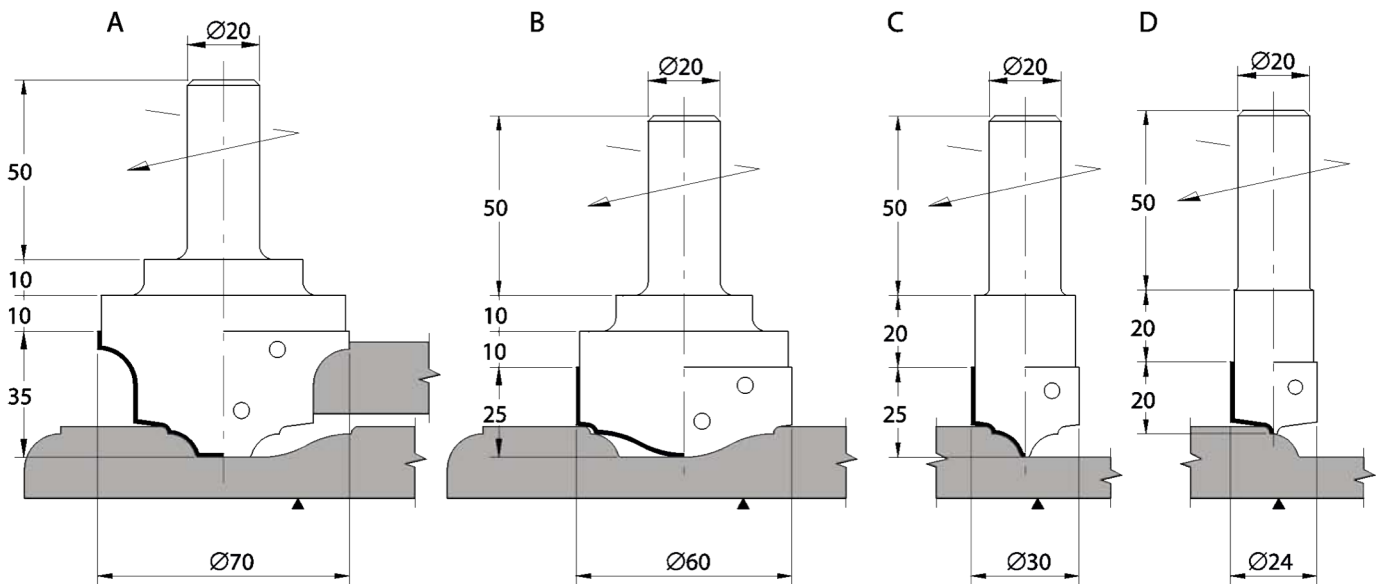

SECTION:

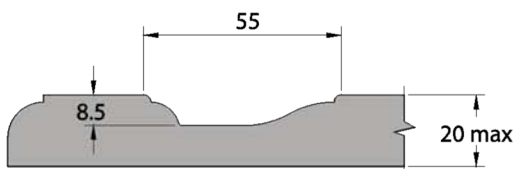

VIEW:

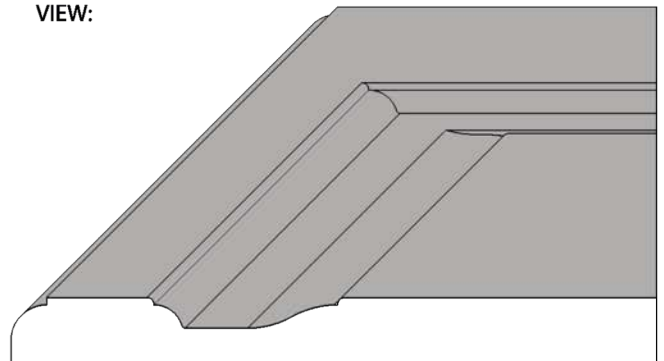



**APPLICATION:**

Production of MDF kitchen doors or decoration of MDF panels.

**MACHINE:**

CNC router.

**TECHNICAL INFORMATION:**

Manufactured with indexable micrograin solid carbide knives. On request we can produce for solid wood with suitable cutting angles. Supplied with cylindrical shank d. 20x50. Increase of 15% for tapered shanks.

**MEC HW**

Code	D	S	Z	Rpm Max	Price Code	Profile	Spare Parts		
							Knife	Screw	Key
5006.000.001	60	40	2	18.000	F23	A	8170.040.040	8330.035.003	8345.015.000
5006.000.002	60	25	2	18.000	H22	B	8170.030.025	8330.035.003	8345.015.000
5006.000.003	30	25	2	20.000	H21	C	8170.015.025	8330.035.003	8345.015.000

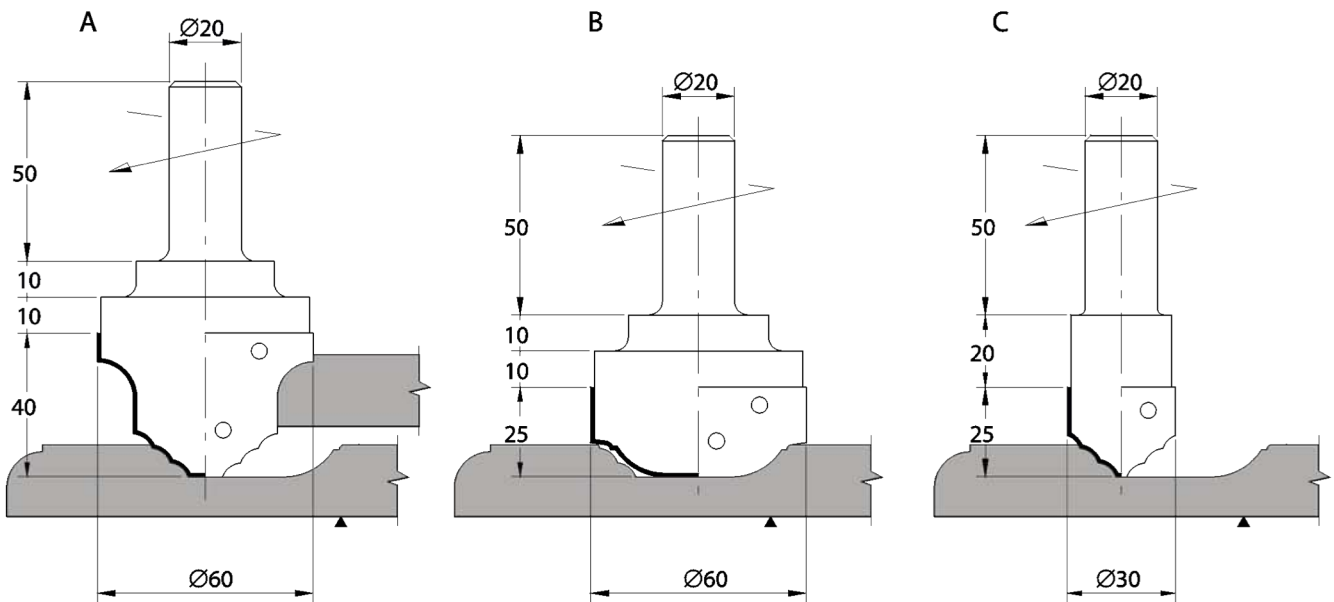

SECTION:

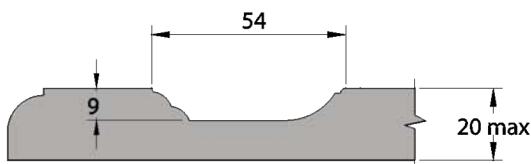

VIEW:

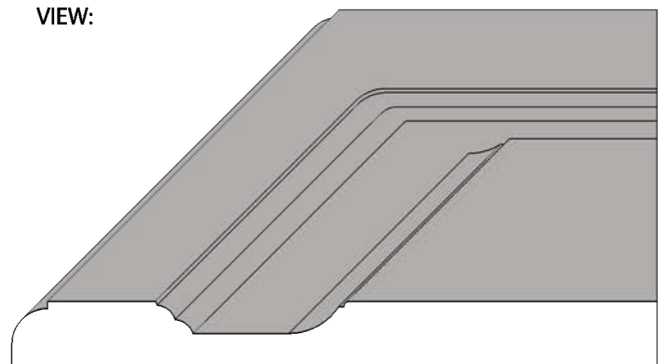





**APPLICATION:**

Production of MDF kitchen doors or decoration of MDF panels.

**MACHINE:**

CNC router.

**TECHNICAL INFORMATION:**

Manufactured with indexable micrograin solid carbide knives. On request we can produce for solid wood with suitable cutting angles. Supplied with cylindrical shank d. 20x50. Increase of 15% for tapered shanks.

**MEC HW**

Code	D	S	Z	Rpm Max	Price Code	Profile	Spare Parts		
							Knife	Screw	Key
5007.000.001	110	50	2	12.000	D28	A	8170.050.030	8330.060.000	8350.040.000
5007.000.002	70	25	2	18.000	H25	B	8170.035.025	8330.035.003	8345.015.000

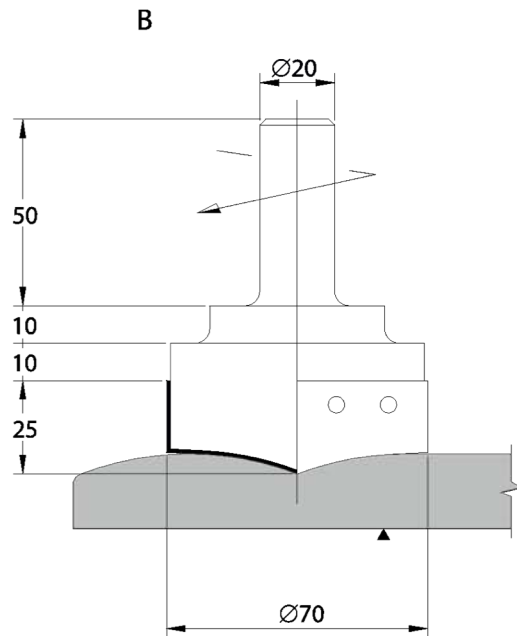
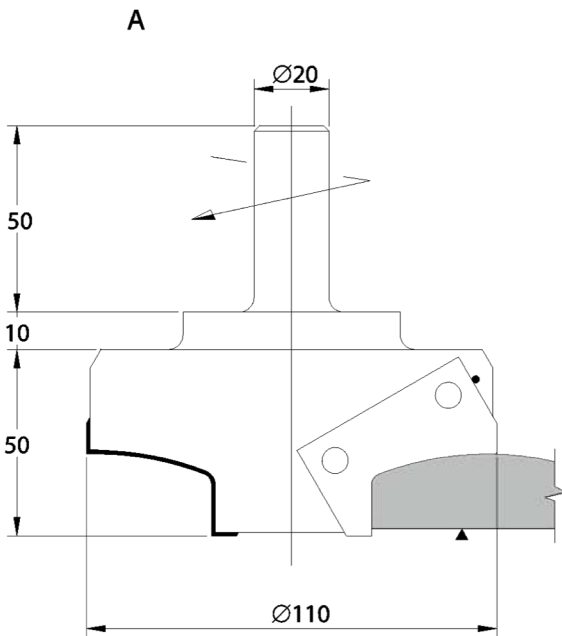

**SECTION:**

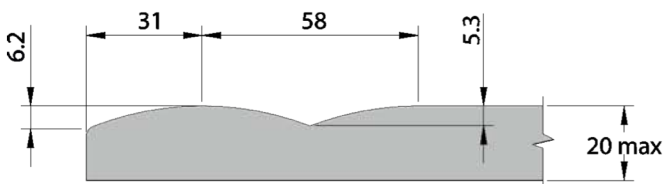

**VIEW:**

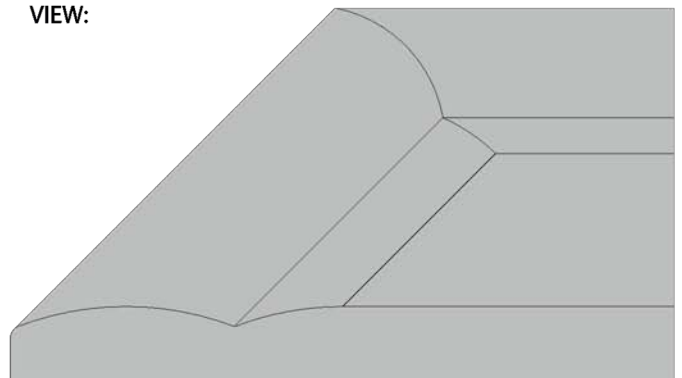

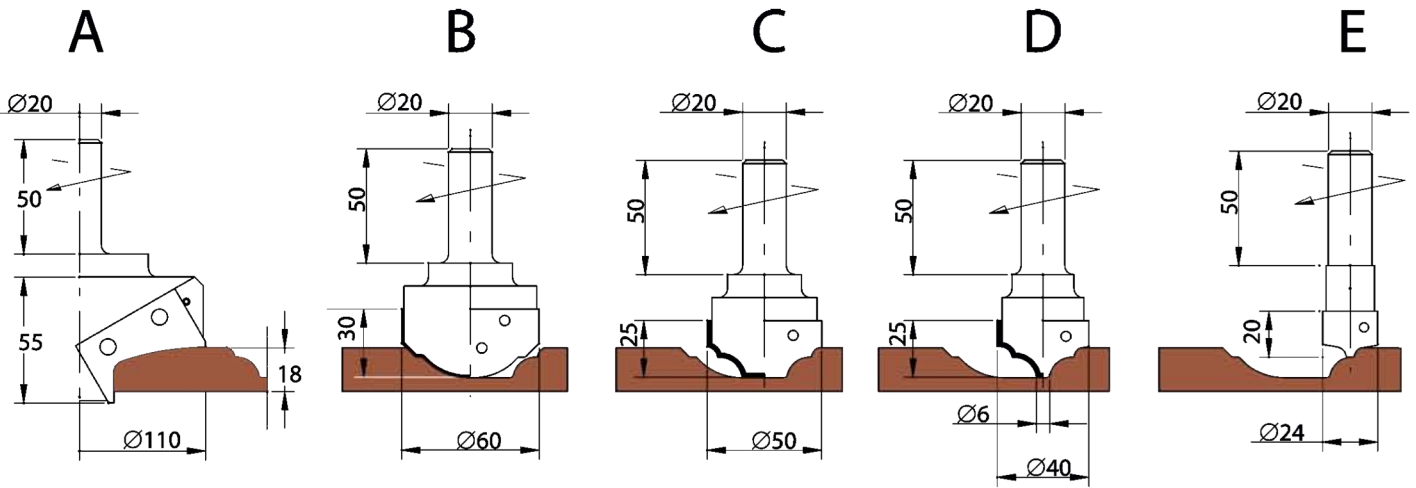

**NESTING SYSTEM :**

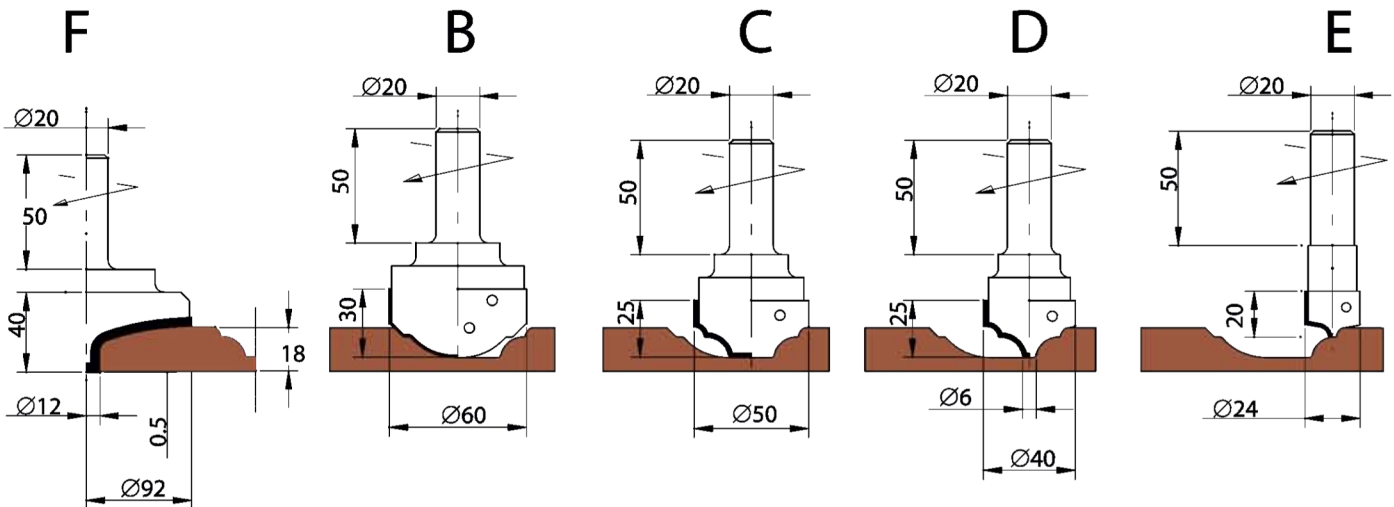

**MEC HW DP**

Code	D	S	Z	Rpm Max	Price Code	Profile	Spare Parts		
							Knife	Screw	Key
5401.000.001	110	55	2	12.000	D28	HW A	8170.050.030	8330.060.000	8350.040.000
5401.000.002	60	30	2	18.000	L22	HW B	8170.030.030	8330.035.003	8345.015.000
5401.000.003	50	25	2	18.000	D22	HW C	8170.025.025	8330.035.003	8345.015.000
5401.000.004	40	25	2	18.000	B22	HW D	8170.020.025	8330.035.003	8345.015.000
5401.000.005	24	20	2	20.000	F20	HW E	8170.020.012	8330.035.003	8345.015.000
6401.000.001	92	40	2	18.000	E36	DP F	-	-	-

For diamond cutters (DP) quotation on request

**VERTICAL SECTION**





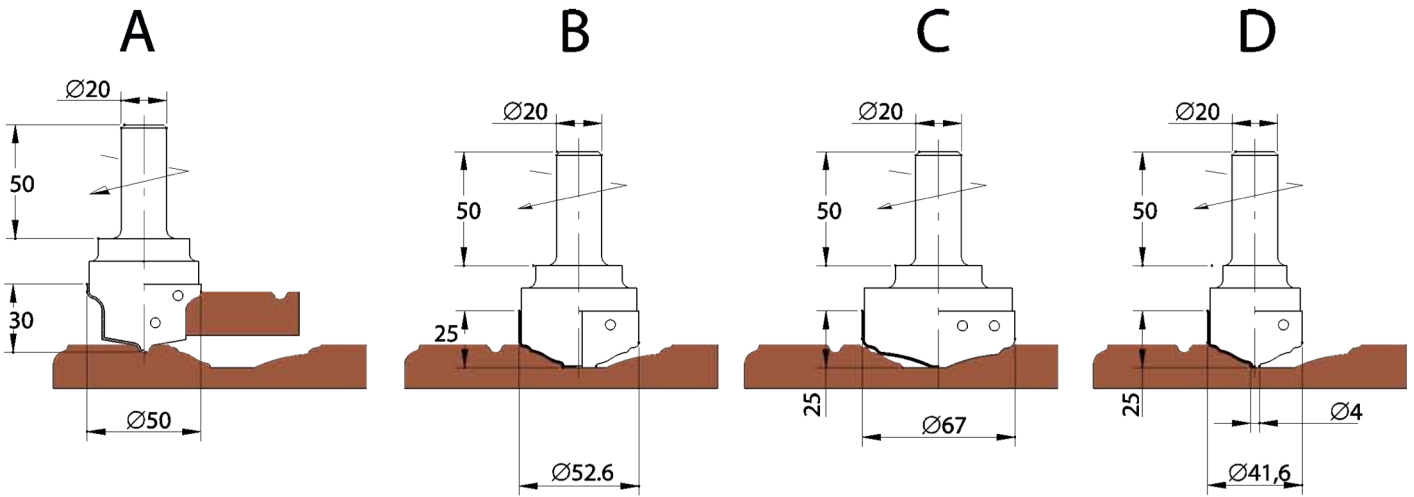

**NESTING SYSTEM :**

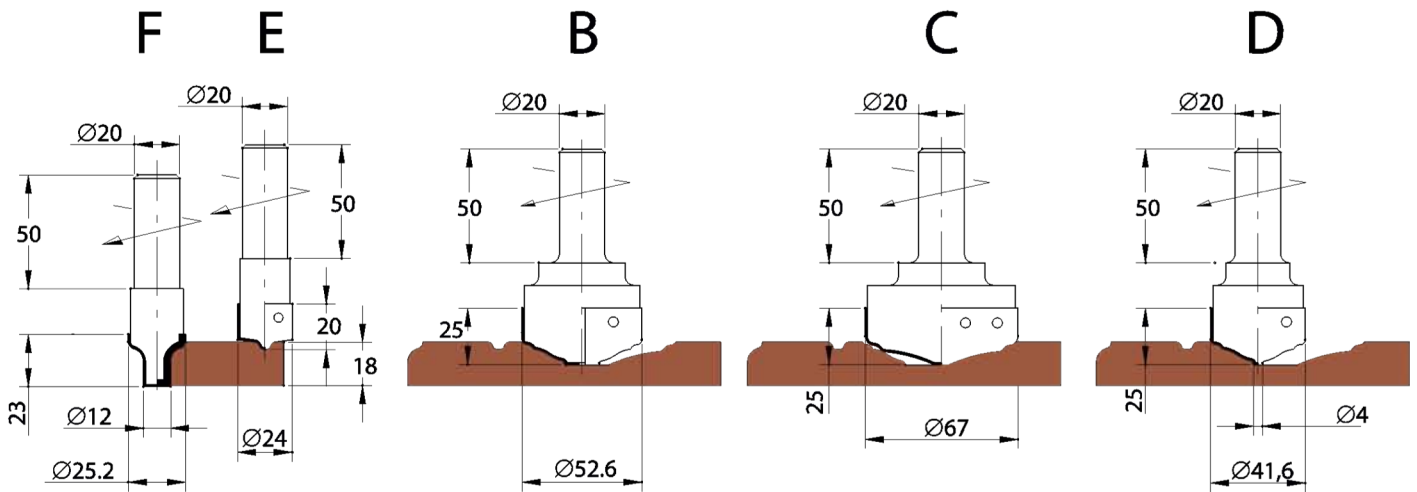

**MEC HW DP**

Code	D	S	Z	Rpm Max	Price Code	Profile	Spare Parts		
							Knife	Screw	Key
5402.000.001	50	30	2	18.000	G22	HW A	8170.030.025	8330.035.003	8345.015.000
5402.000.002	52,6	25	2	18.000	D22	HW B	8170.025.025	8330.035.003	8345.015.000
5402.000.003	67	25	2	16.000	H25	HW C	8170.035.025	8330.035.003	8345.015.000
5402.000.004	41,6	25	2	20.000	B22	HW D	8170.025.025	8330.035.003	8345.015.000
5402.000.005	24	20	2	20.000	F20	HW E	8170.020.012	8330.035.003	8345.015.000
6402.000.001	25,2	23	2	20.000	E28	DP F	-	-	-

**VERTICAL SECTION**





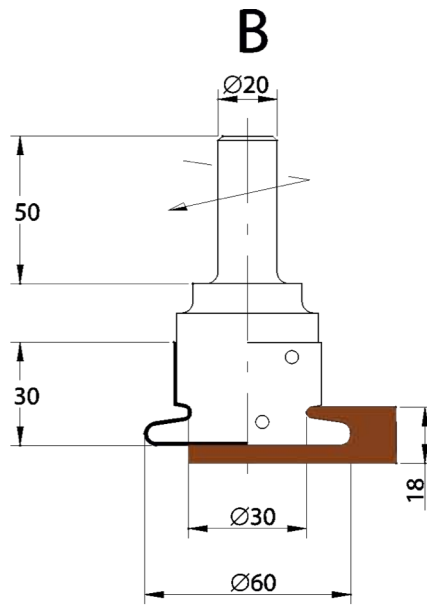
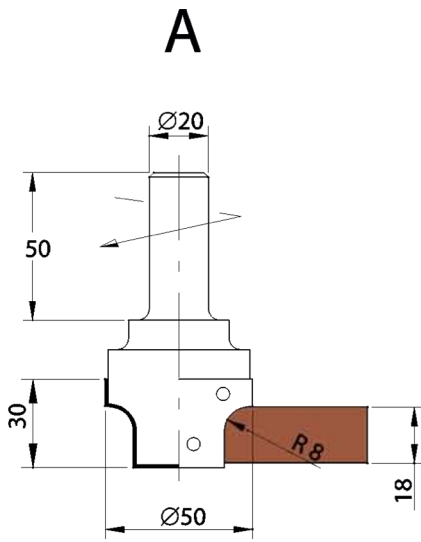

NESTING SYSTEM :

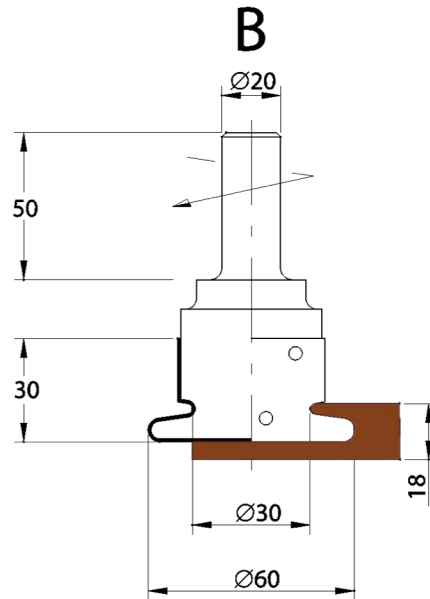
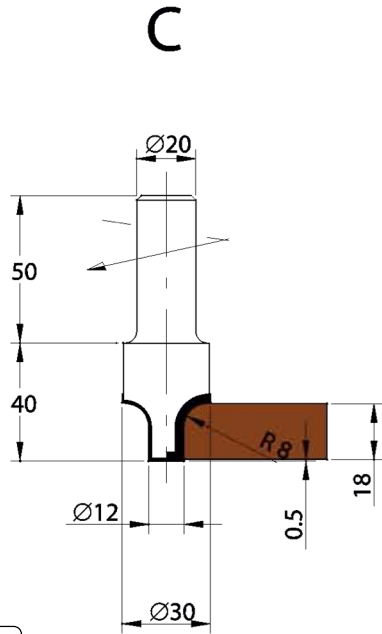

**MEC** **HW** **DP**

Code	D	S	Z	Rpm Max	Price Code	Profile	Spare Parts		
							Knife	Screw	Key
5403.000.001	50	30	2	18.000	G22	HW A	8170.030.025	8330.035.003	8345.015.000
5403.000.002	60	30	2	16.000	L22	HW B	8170.030.030	8330.035.003	8345.015.000
6403.000.001	30	40	2	20.000	E29	DP C	-	-	-

For diamond cutters (DP) quotation on request

**VERTICAL SECTION**



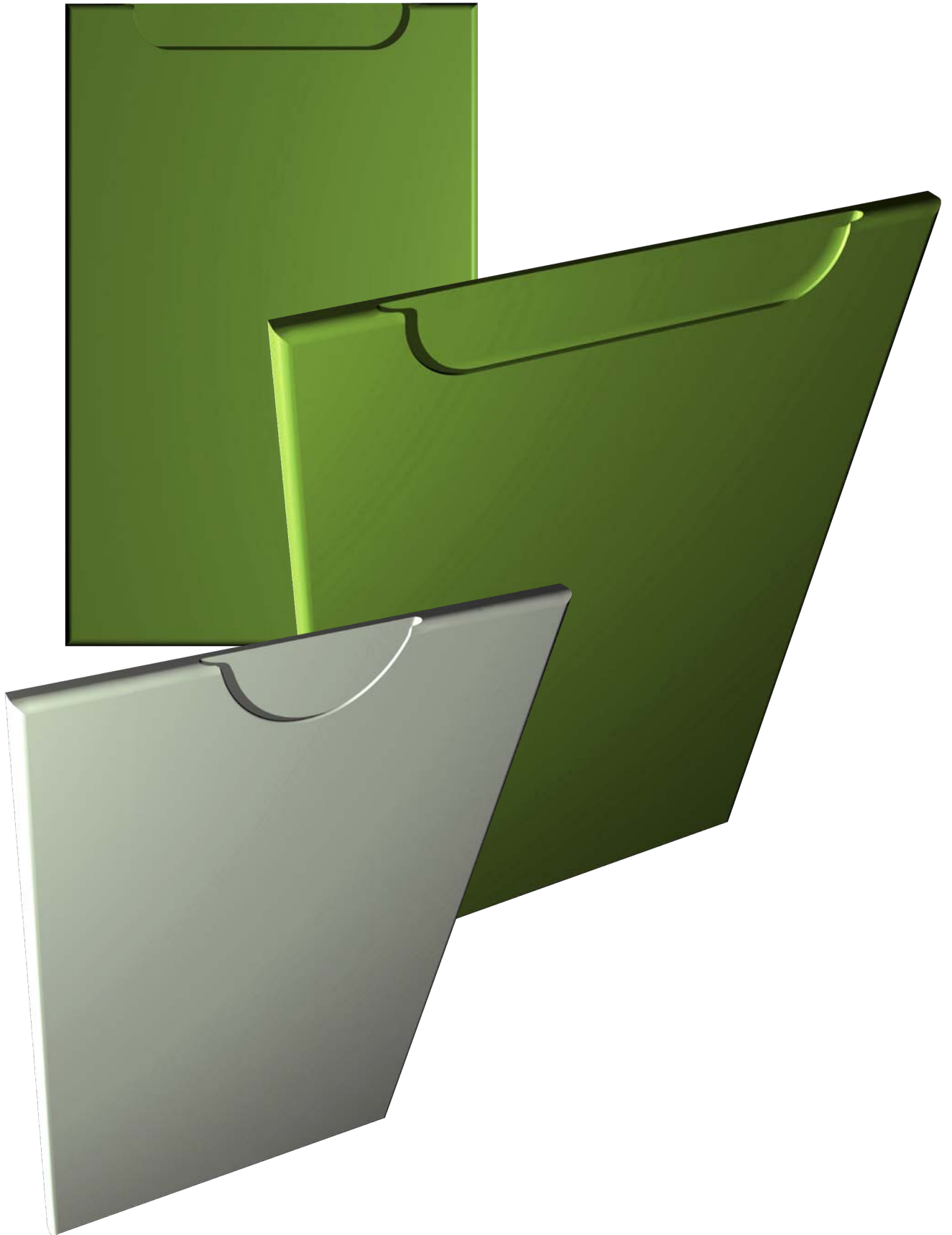



**APPLICATION:**

Production of solid wood kitchen doors.

**MACHINE:**

CNC router.

**TECHNICAL INFORMATION:**

Manufactured with indexable micrograin solid carbide knives.

Produced with suitable cutting angles for different types of wood.

Supplied with cylindrical shank d. 20x50.

**MEC HW**

Code	D	S	Z	Rpm Max	Price Code	Profile	Spare Parts			
							Knife	Screw	Wedge	Spur
5008.000.001	100	38	2	12.000	D30	A	A1-8170.020.030	8285.008.000	8280.160.000	
							A2-8170.020.025	8285.008.000	8280.160.000	
5008.000.002	100	38	2	12.000	L31	B	B1-8170.020.030	8285.008.000	8280.160.000	8120.140.002
							B2-8170.020.025	8285.008.000	8280.160.000	
5008.000.003	110	25	2	12.000	G25	C	8170.040.025	8330.035.003		
5008.000.004	30	12	3	12.000	E16	D	8105.120.012	8330.035.002		
5008.000.005	70	35	2	16.000	L23	E	8170.035.035	8330.035.003		

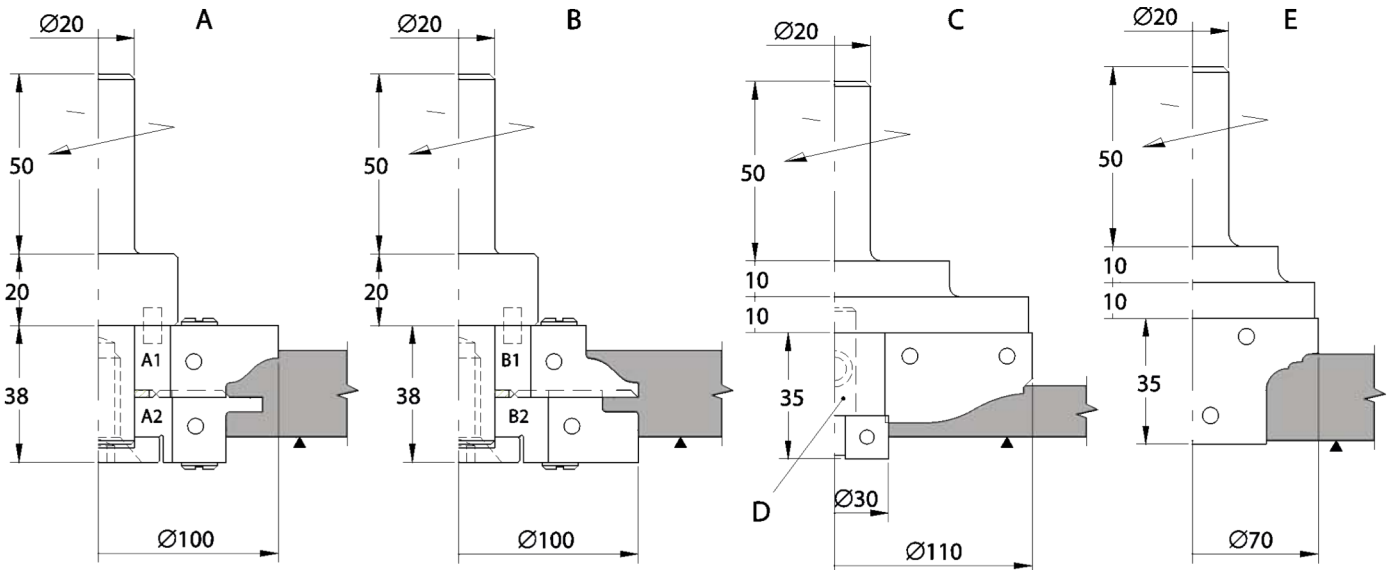

**SECTION:**

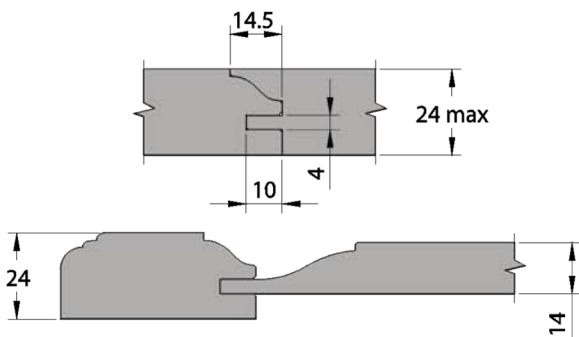

**VIEW:**

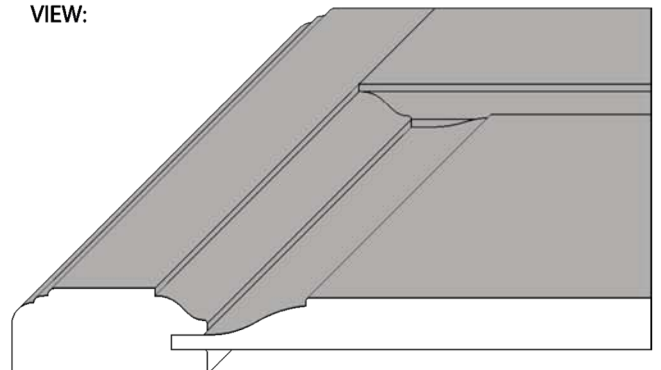





**APPLICATION:**

Production of solid wood kitchen doors.

**MACHINE:**

CNC router.

**TECHNICAL INFORMATION:**

Manufactured with indexable micrograin solid carbide knives.

Produced with suitable cutting angles for different types of wood.

Supplied with cylindrical shank d. 20x50.

**MEC HW**

Code	D	S	Z	Rpm Max	Price Code	Profile	Spare Parts			
							Knife	Screw	Wedge	Key
5009.000.001	110	49	2	12.000	D33	A	A1-8170.025.030	8285.008.000	8280.210.000	8350.040.000
							A2-8170.025.025	8285.008.000	8280.210.000	8350.040.000
5009.000.002	110	25	2	12.000	G25	B	8170.035.025	8330.035.003		8345.015.000
5009.000.003	30	12	3	12.000	E16	C	8105.120.012	8330.035.002		8345.015.000
5009.000.004	110	50	2	12.000	M28	D	8170.050.030	8330.060.000		8350.040.000

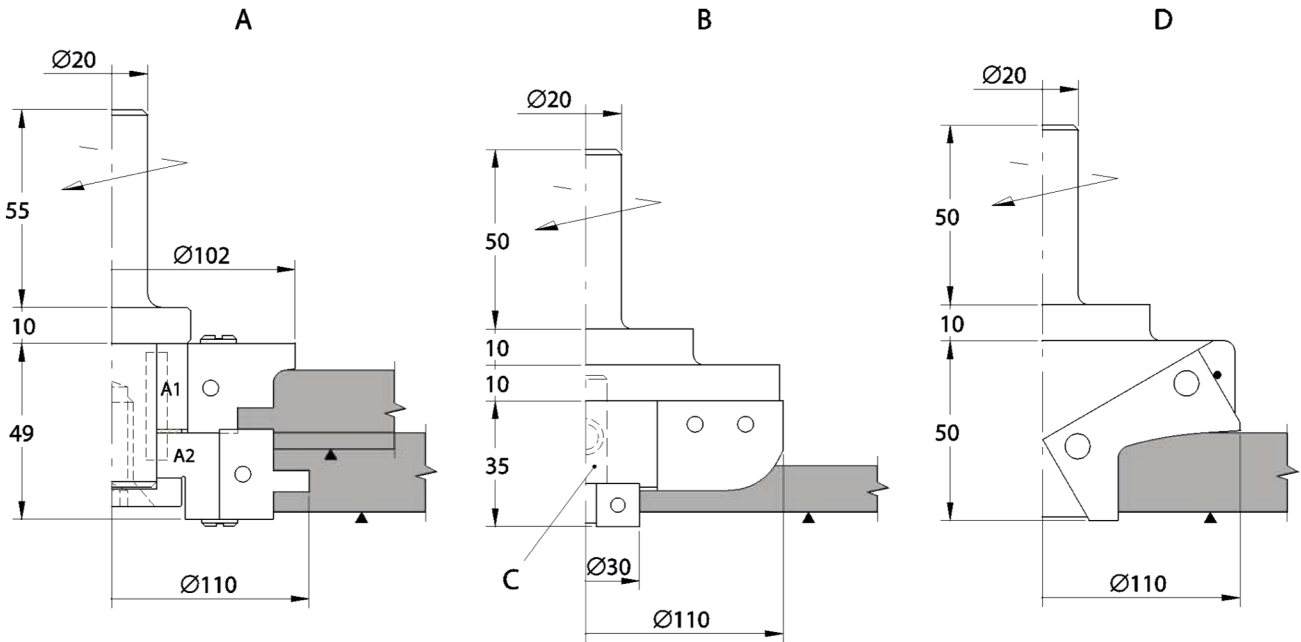

SECTION:

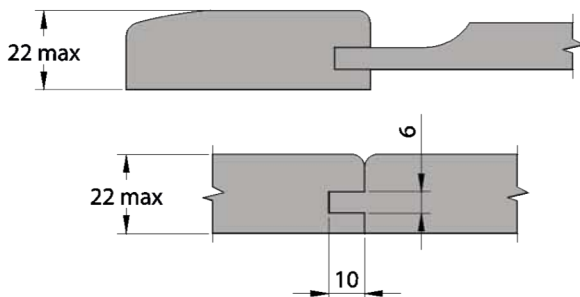

VIEW:

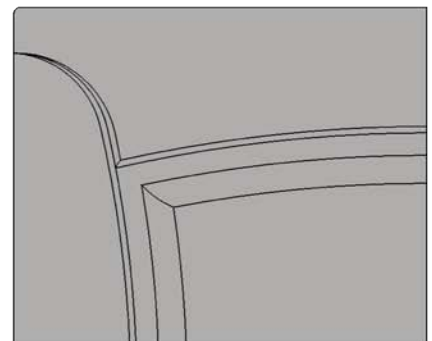

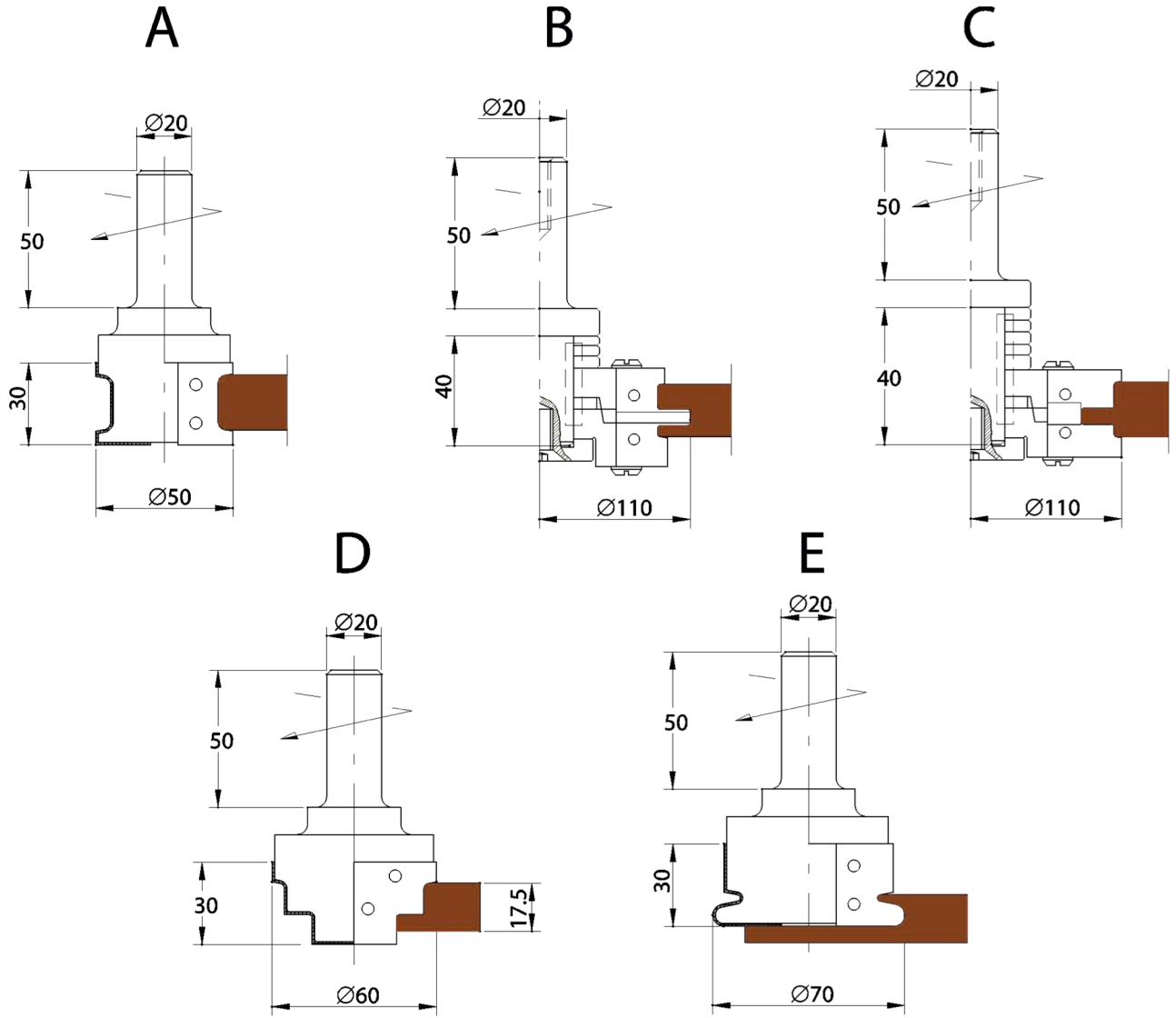

**MEC HW**

Code	D	S	Z	Rpm Max	Price Code	Profile	Spare Parts			
							Knife	Screw	Wedge	Key
5404.000.001	50	30	2	18.000	G22	HW A	8170.030.020	8330.035.003	-	8345.015.000
5404.000.002	110	40	2	12.000	L31	HW B	8170.020.030	8285.008.000	8280.160.000	8350.040.000
5404.000.003	110	40	2	12.000	L31	HW C	8170.020.030	8285.008.000	8280.160.000	8350.040.000
5404.000.004	60	30	2	18.000	L22	HW D	8170.030.030	8330.035.003	-	8345.015.000
5404.000.005	70	30	2	16.000	B24	HW E	8170.030.025	8330.035.003	-	8345.015.000

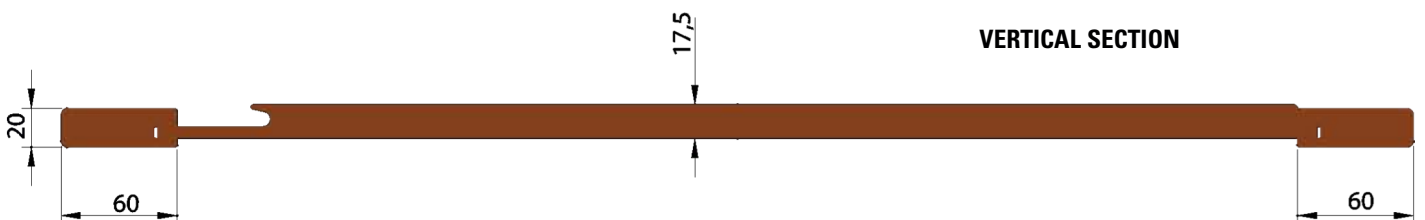

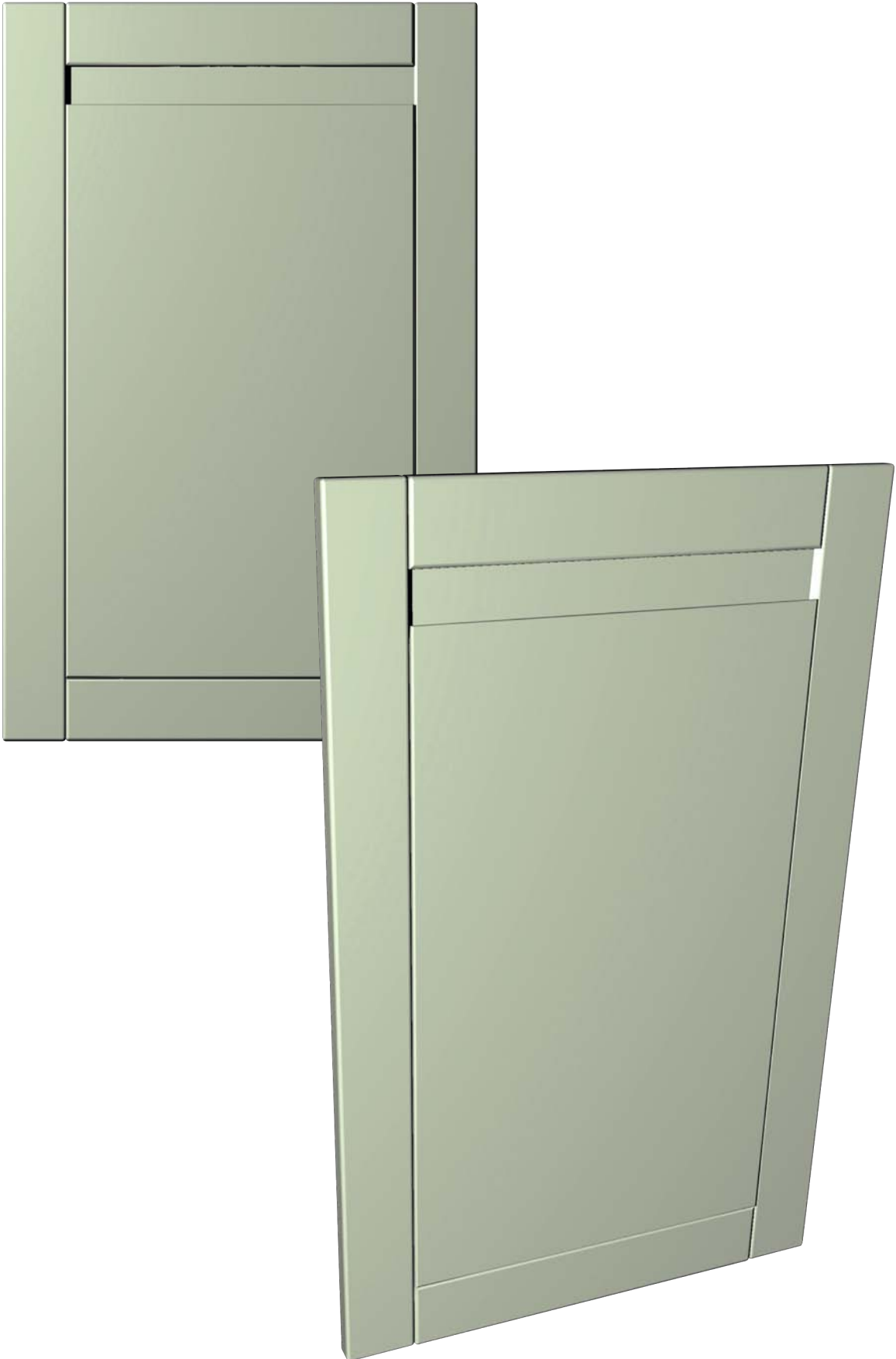

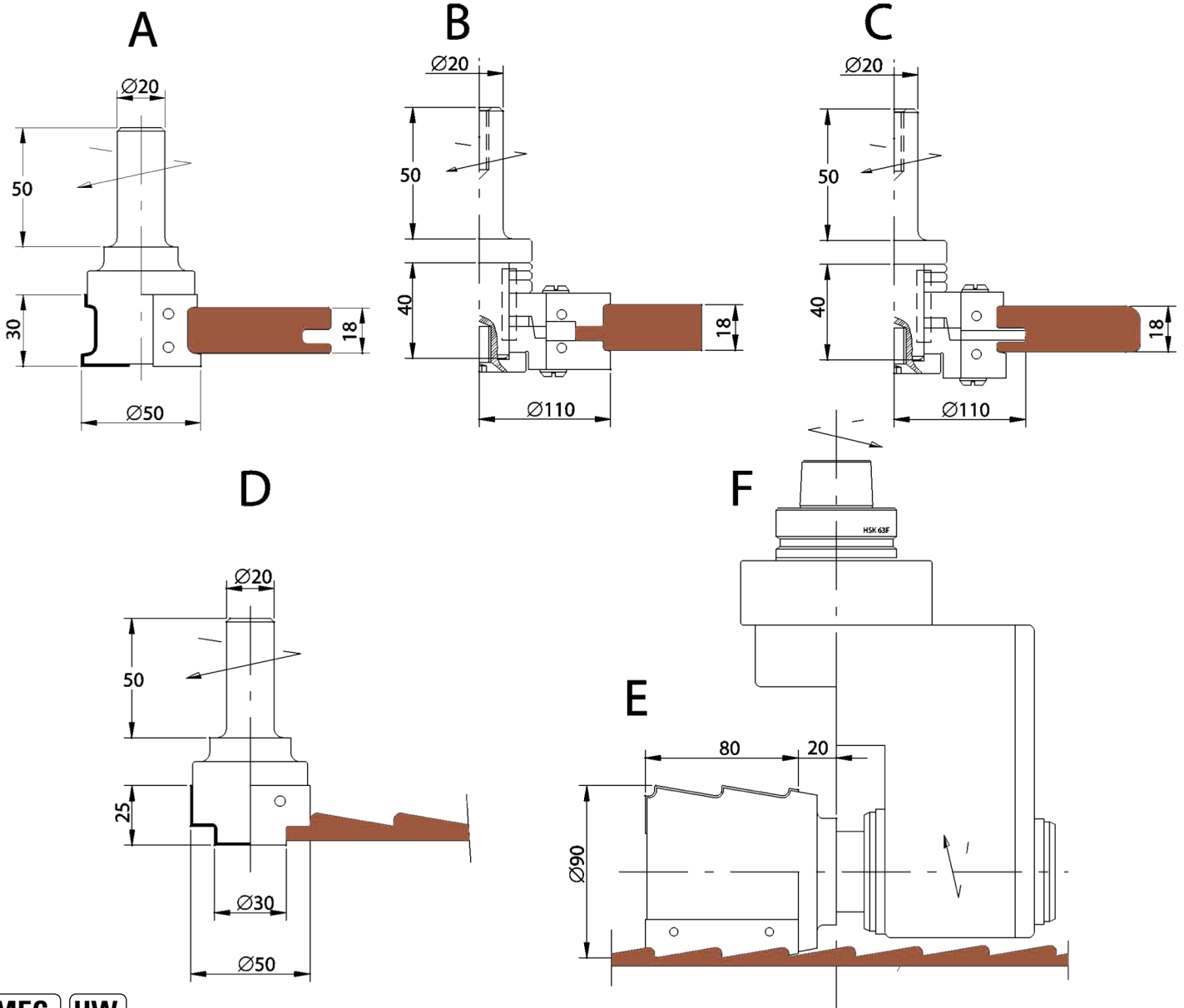

**MEC HW**

Code	D	S	Z	Rpm Max	Price Code	Profile	Spare Parts			
							Knife	Screw	Wedge	Key
5405.000.001	50	30	2	18.000	G22	HW A	8170.030.025	8330.035.003	-	8345.015.000
5405.000.002	110	40	2	12.000	L31	HW B	8170.020.030	8285.008.000	8280.160.000	8350.040.000
5405.000.003	110	40	2	12.000	L31	HW C	8170.020.030	8285.008.000	8280.160.000	8350.040.000
5405.000.004	50	25	2	18.000	D22	HW D	8170.025.025	8330.035.000	-	8345.015.000
5405.000.005	90	80	2	9.000	L29	HW E	8175.080.020	8330.060.000	-	8350.040.000

For aggregate "F" quotation on request

**VERTICAL SECTION**

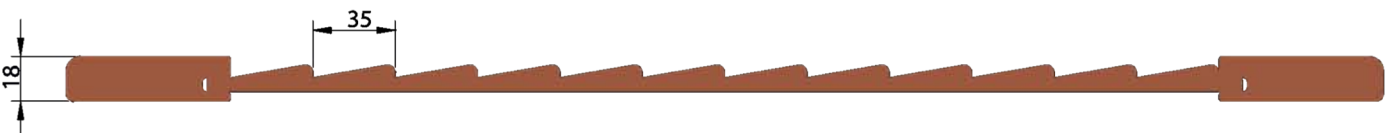

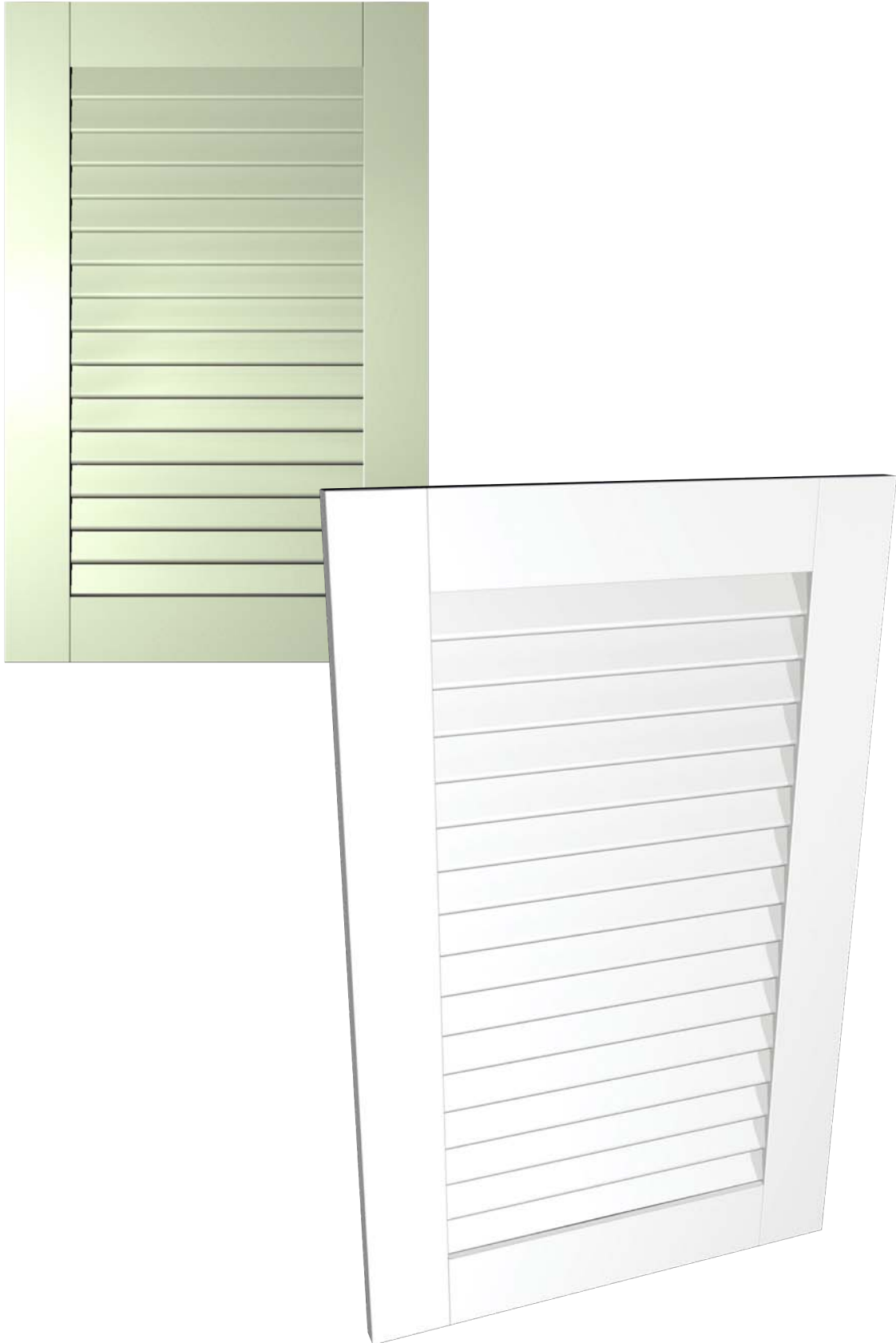



**APPLICATION:**

Production of different profiles on request.

**MACHINE:**

CNC router.

**TECHNICAL INFORMATION:**

Manufactured with indexable micrograin solid carbide knives. Produced with suitable cutting angles for different types of wood. Supplied with cylindrical shank d. 20x50 or d. 25x55. Increase of 15% for tapered shanks.

**MEC** **HW** **Z=2**

Code	D	S	Rpm Max	Price Code	Code	D	S	Rpm Max	Price Code
5010.024.020	24	20	20.000	C21	5010.060.040	60	40	18.000	D24
5010.024.025	24	25	20.000	M21	5010.060.050	60	50	16.000	M24
5010.030.020	30	20	20.000	A22	5010.060.060	60	60	16.000	G26
5010.030.025	30	25	20.000	F22	5010.070.030	70	30	18.000	M24
5010.030.030	30	30	20.000	M22	5010.070.035	70	35	16.000	C25
5010.040.020	40	20	18.000	A22	5010.070.040	70	40	16.000	F25
5010.040.025	40	25	18.000	F22	5010.070.050	70	50	16.000	C26
5010.040.030	40	30	18.000	M22	5010.070.060	70	60	16.000	D27
5010.040.035	40	35	18.000	D23	5010.080.030	80	30	18.000	B25
5010.040.040	40	40	18.000	H23	5010.080.035	80	35	16.000	F25
5010.040.050	40	50	18.000	D24	5010.080.040	80	40	16.000	L25
5010.040.060	40	60	16.000	M25	5010.080.050	80	50	14.000	F26
5010.050.020	50	20	18.000	F22	5010.080.060	80	60	14.000	G27
5010.050.025	50	25	18.000	M22	5010.100.040	100	40	12.000	C27
5010.050.030	50	30	18.000	D23	5010.100.050	100	50	12.000	L27
5010.050.035	50	35	18.000	L23	5010.100.060	100	60	10.000	B29
5010.050.040	50	40	18.000	A24	5010.100.080	100	80	9.000	L29
5010.050.050	50	50	18.000	H24	5010.120.040	120	40	12.000	L28
5010.050.060	50	60	16.000	E26	5010.120.050	120	50	12.000	F29
5010.060.030	60	30	18.000	H23	5010.120.060	120	60	10.000	E30
5010.060.035	60	35	18.000	A24	5010.120.080	120	80	8.000	H31

Spare Parts	Article
knife	8170-8175
Screw	8330
Key	8345-8350

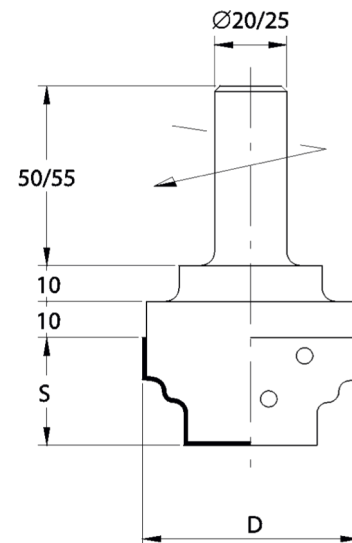



**APPLICATION:**  
Half radius panel profiling.

**MACHINE:**  
CNC router.

**TECHNICAL INFORMATION:**  
Manufactured with indexable micrograin solid carbide knives. Produced with suitable cutting angles for different types of wood. In the order please state the radius and material to be worked. Supplied with cylindrical shank d. 20x50. Increase of 15% for tapered shanks.

**MEC HW Z=2**

Code	D	S	Rpm Max	Price Code	Radius	Spare Parts		
						Knife	Screw	Key
5011.000.001	60	30	18.000	L22	4:9	8170.030.030	8330.035.003	8345.015.000
5011.000.002	70	40	16.000	G24	10:14	8170.040.035	8330.035.003	8345.015.000
5011.000.003	80	50	14.000	G25	15:20	8170.050.040	8330.060.000	8350.040.000

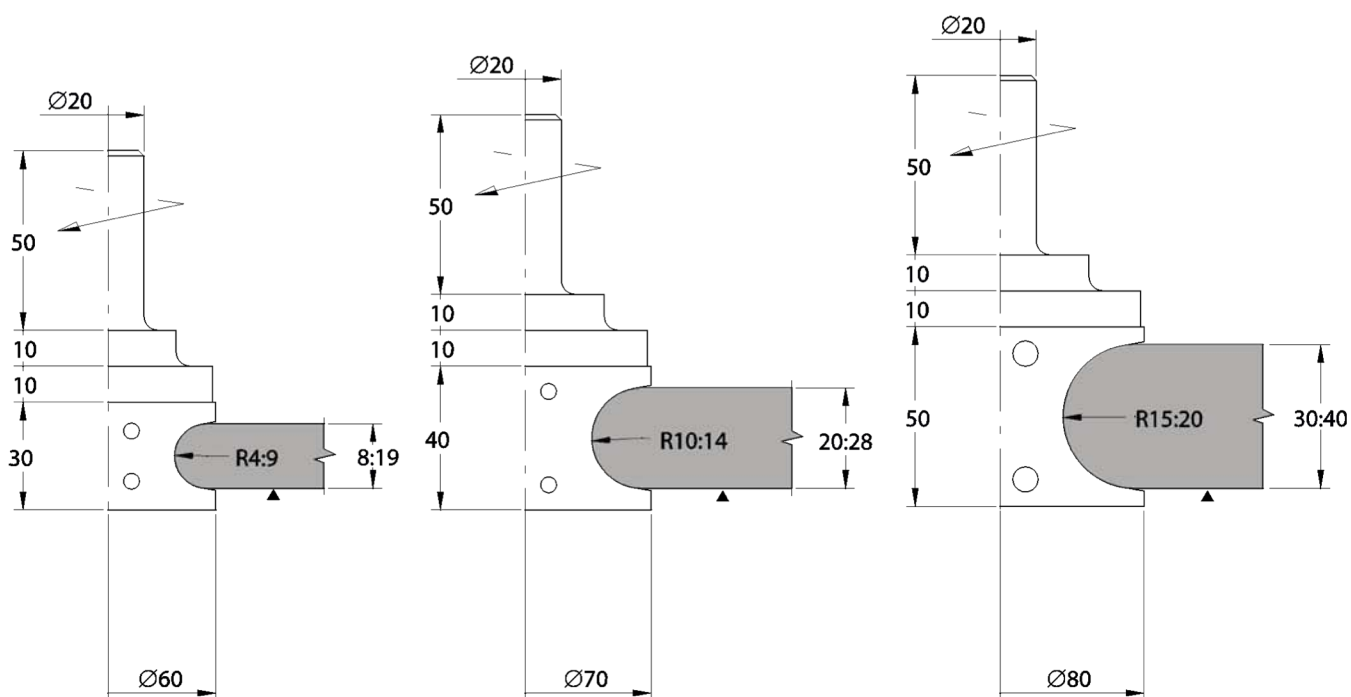



**APPLICATION:**

Quarter round cnc router cutters.

**MACHINE:**

CNC router.

**TECHNICAL INFORMATION:**

Manufactured with indexable micrograin solid carbide knives. Produced with suitable cutting angles for different types of wood. In the order please state the radius and material to be worked. Supplied with cylindrical shank d. 20x50. Increase of 15% for tapered shanks.

**MEC HW Z=2**

Code	D	S	Rpm Max	Price Code	Radius	Spare Parts		
						Knife	Screw	Key
5012.000.001	50	30	18.000	E22	4:9	8170.030.025	8330.035.003	8345.015.000
5012.000.002	60	30	18.000	L22	10:14	8170.030.030	8330.035.003	8345.015.000
5012.000.003	70	35	16.000	E24	15:20	8170.035.035	8330.035.003	8345.015.000

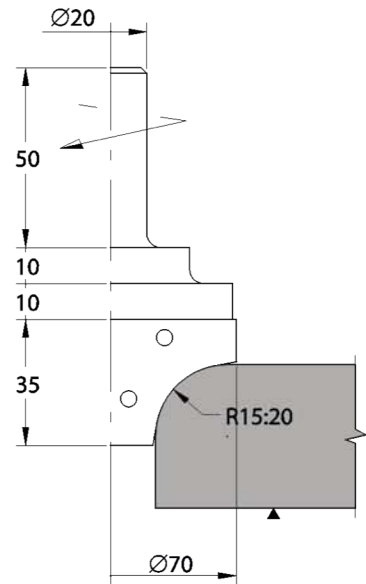
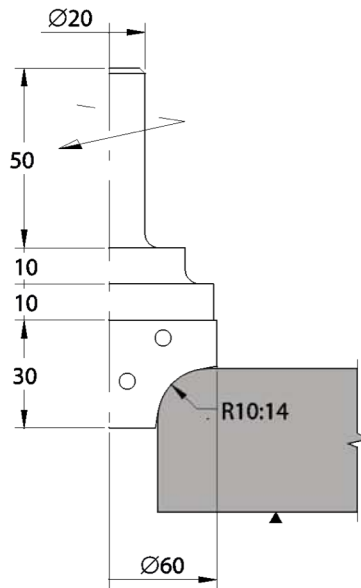
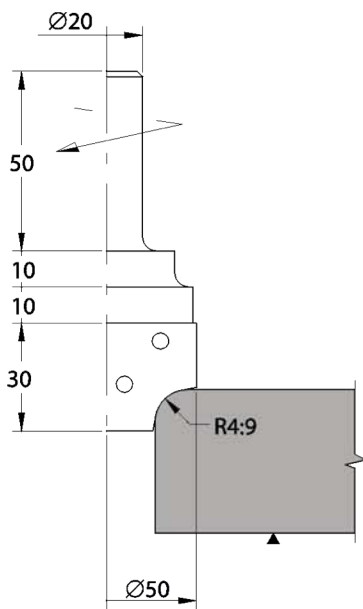





**APPLICATION:**

Panel cutting with radius or bevel adjustable inserts.

**MACHINE:**

CNC router.

**TECHNICAL INFORMATION:**

Manufactured with indexable micrograin solid carbide knives. Produced with suitable cutting angles for different types of wood. In the order please state type of bevelling insert and material to be worked. Supplied with cylindrical shank d. 20x50 or d. 25x55. Cutter body made by "Ergal" light alloy.

**MEC HW Z=2+4**

Code	D	S	Z	Rpm Max	H max	Price Code	Spare Parts			
							Knife	Screw	Wedge	Key
5013.000.001	100	50	2+4	12.000	50	H28	8105.500.012	8285.008.000	8280.460.000	8350.040.000
5013.000.002	100	60	2+4	12.000	60	M29	8105.600.012	8285.008.000	8280.560.000	8350.040.000

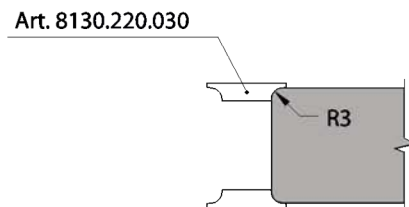
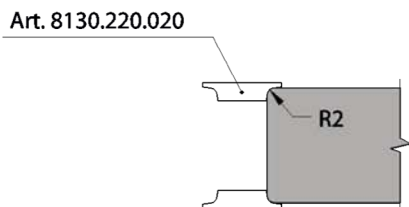
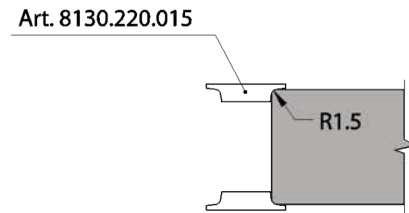
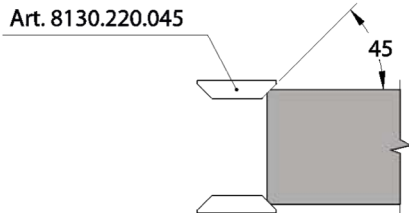
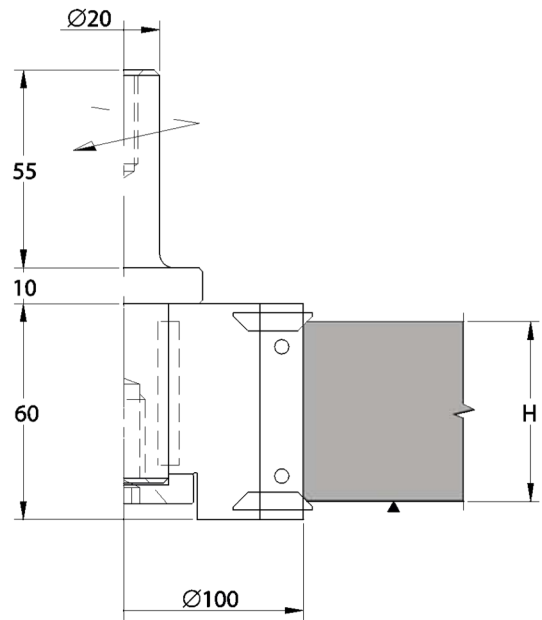
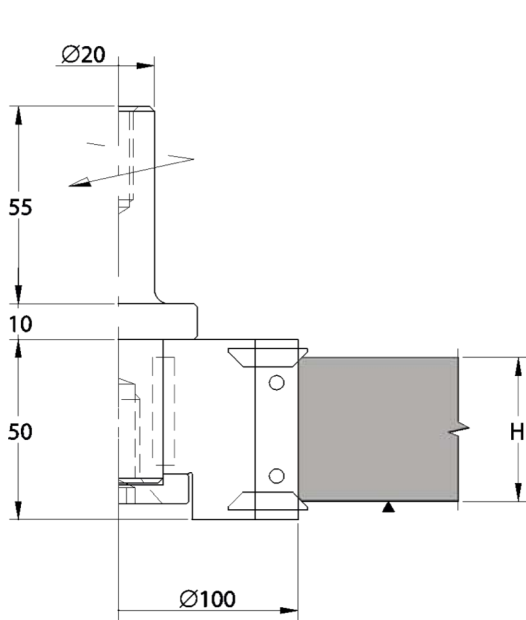



**APPLICATION:**

Adjustable thickness CNC router cutter with radius inserts.

**MACHINE:**

CNC router.

**TECHNICAL INFORMATION:**

Manufactured with indexable micrograin solid carbide knives. Produced with suitable cutting angles for different types of wood. In the order please state the required radius and material to be worked. Supplied with cylindrical shank d. 20x50 or d. 25x55. Cutter body made by "Ergal" light alloy.

**MEC HW Z=2**

Code	D	S	R	Rpm Max	H max	Price Code	Spare Parts			
							Knife	Screw	Wedge	Key
5014.000.001	120	56	4÷10	12.000	20÷38	C34	8170.020.030	8285.008.000	8280.160.000	8350.040.000
							8170.040.030	8285.008.000	8280.360.000	8350.040.000
5014.000.002	120	66	4÷10	11.000	30÷48	L34	8170.020.030	8285.008.000	8280.160.000	8350.040.000
							8170.050.030	8285.008.000	8280.460.000	8350.040.000

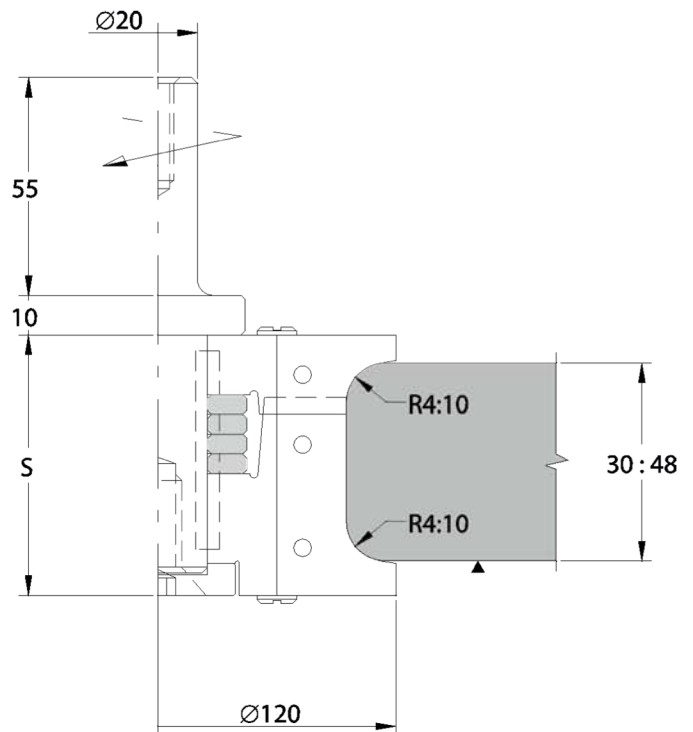
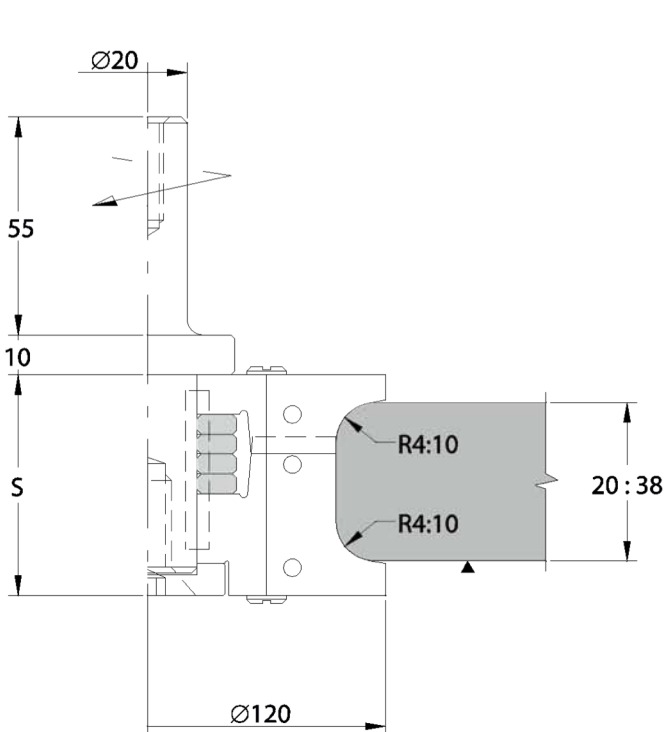



**APPLICATION:**

Production of solid wood doors profiles.

**MACHINE:**

CNC router.

**TECHNICAL INFORMATION:**

Manufactured with indexable micrograin solid carbide knives. Produced with suitable cutting angles for different types of wood. In the order please state the required profile and material to be worked. Supplied with cylindrical shank d. 20x50 or d.25x55.

**MEC HW Z=2**

Code	D	S	P Max	Rpm Max	H max	Price Code	Spare Parts			
							Knife	Screw	Wedge	Key
5015.000.001	110	46	10	12.000	24	M32	8170.020.025	8285.008.000	8280.160.000	8350.040.000
							8170.020.025	8285.008.000	8280.160.000	8350.040.000
5015.000.002	120	46	15	12.000	24	F33	8170.020.030	8285.008.000	8280.160.000	8350.040.000
							8170.020.030	8285.008.000	8280.160.000	8350.040.000
5015.000.003	130	46	20	11.000	24	D34	8170.020.035	8285.008.000	8280.160.000	8350.040.000
							8170.020.030	8285.008.000	8280.160.000	8350.040.000

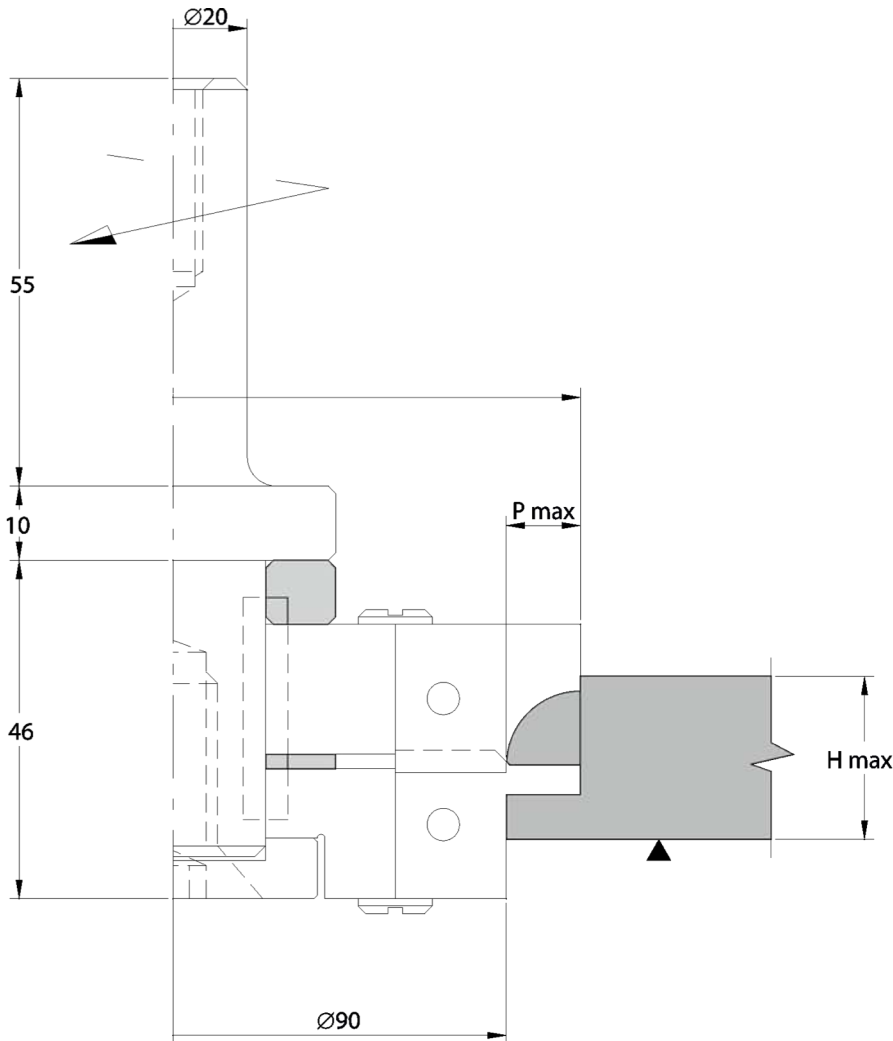

**PROFILE SAMPLES**

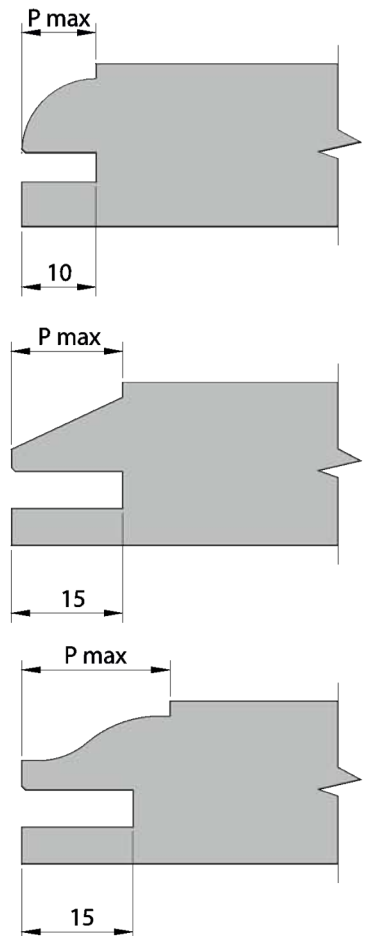



**APPLICATION:**

Solid wood doors counterprofiles (tenoning).

**MACHINE:**

CNC router.

**TECHNICAL INFORMATION:**

Manufactured with indexable micrograin solid carbide knives. Produced with suitable cutting angles for different types of wood. In the order please state the required profile and material to be worked. Supplied with cylindrical shank d. 20x50 or d.25x55.

**MEC HW Z=2**

Code	D	S	P Max	Rpm Max	H max	Price Code	Spare Parts			
							Knife	Screw	Wedge	Key
5016.000.001	110	46	10	12.000	24	M32	8170.020.025	8285.008.000	8280.160.000	8350.040.000
							8170.020.025	8285.008.000	8280.160.000	8350.040.000
5016.000.002	120	46	15	12.000	24	F33	8170.020.030	8285.008.000	8280.160.000	8350.040.000
							8170.020.030	8285.008.000	8280.160.000	8350.040.000
5016.000.003	130	46	20	11.000	24	D34	8170.020.035	8285.008.000	8280.160.000	8350.040.000
							8170.020.030	8285.008.000	8280.160.000	8350.040.000

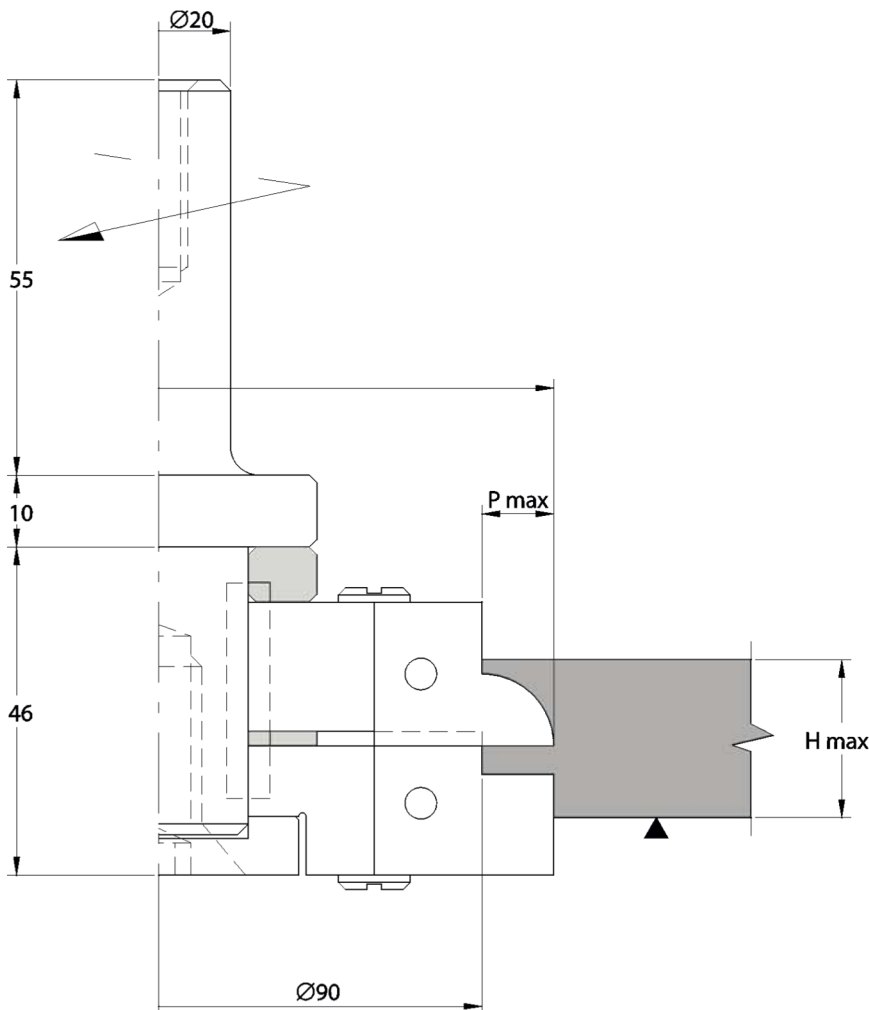

**PROFILE SAMPLES**

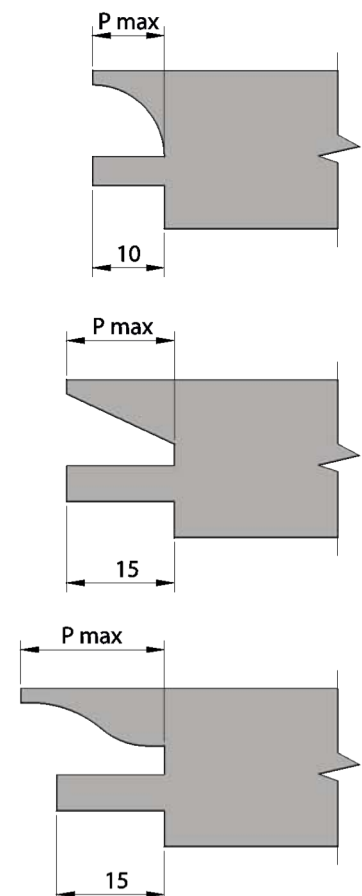



**APPLICATION:**

Production of finger jointing profiles.

**MACHINE:**

CNC router.

**TECHNICAL INFORMATION:**

Manufactured with indexable micrograin solid carbide knives. Produced with suitable cutting angles for different types of wood. In the order please state the material to be worked and the joint required (tight, loose, end grain, cross grain). Supplied with cylindrical shank d. 20x50 or d.25x55. Increase of 15% for tapered shanks.

**MEC HW Z=2**

Code	D	S	P	Rpm Max	H	Price Code	Spare Parts		
							Knife	Screw	Key
5017.000.001	60	30	10	18.000	18÷26	M25	8230.030.010	8330.035.003	8345.015.000
5017.000.002	60	40	10	18.000	26÷36	H26	8230.040.010	8330.035.003	8345.015.000
5017.000.003	60	50	10	18.000	33÷46	E27	8230.050.010	8330.035.003	8345.015.000

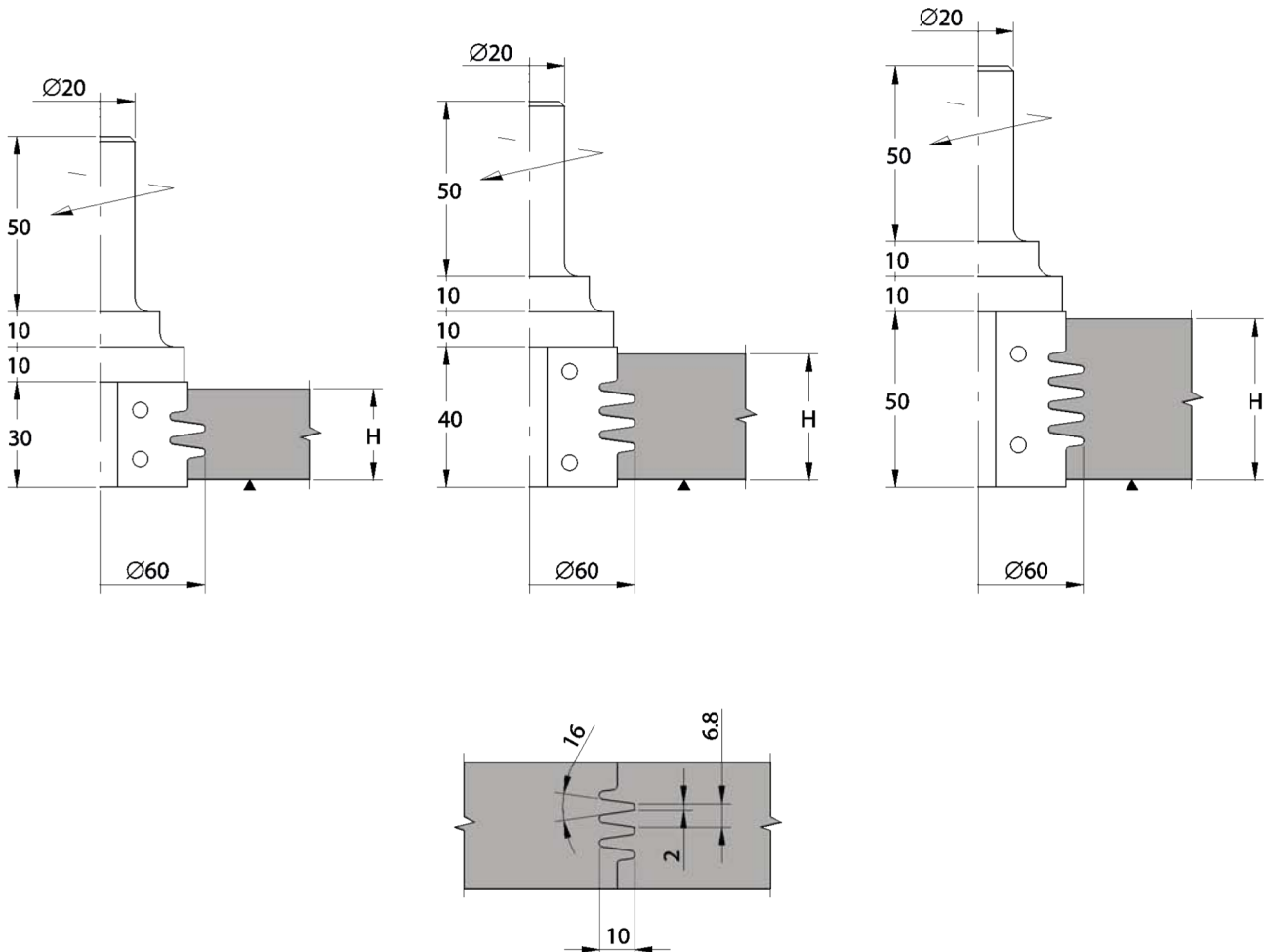



**APPLICATION:**  
45 degrees panel jointing.

**MACHINE:**  
CNC router.

**TECHNICAL INFORMATION:**  
Manufactured with indexable micrograin solid carbide knives. Produced with suitable cutting angles for different types of wood. In the order please state the material to be worked. Supplied with cylindrical shank d. 20x50 or d. 25x55. Increase of 15% for tapered shanks.

**MEC HW Z=2**

Code	D	S	H	Rpm Max	Price Code	Profile	Spare Parts		
							Knife	Screw	Key
5018.000.001	80	40	16÷30	16.000	L25	A	8170.040.040	8330.035.003	8345.015.000
5018.000.002	80	40	16÷30	16.000	L25	B	8170.040.040	8330.035.003	8345.015.000

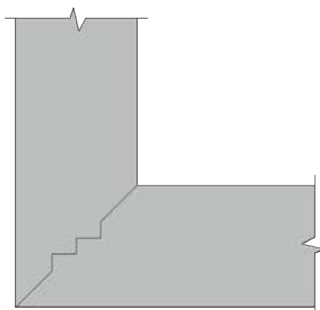
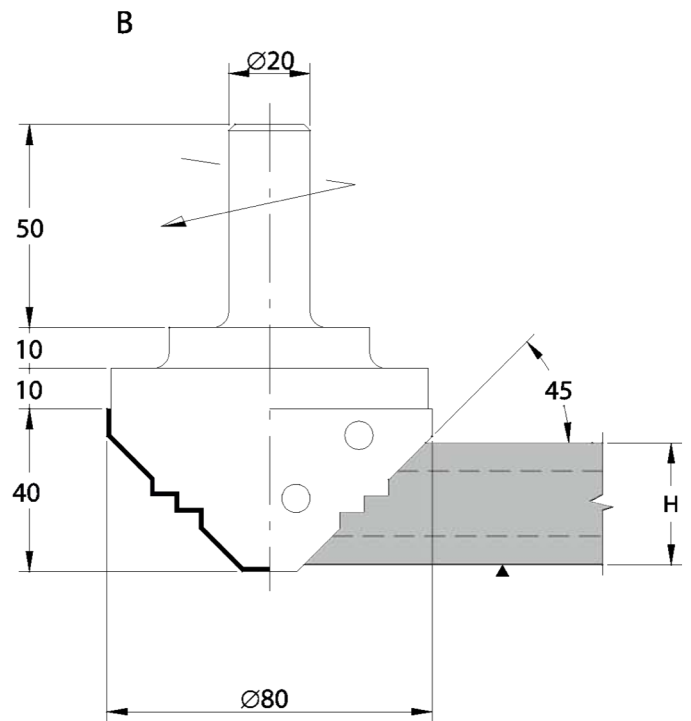
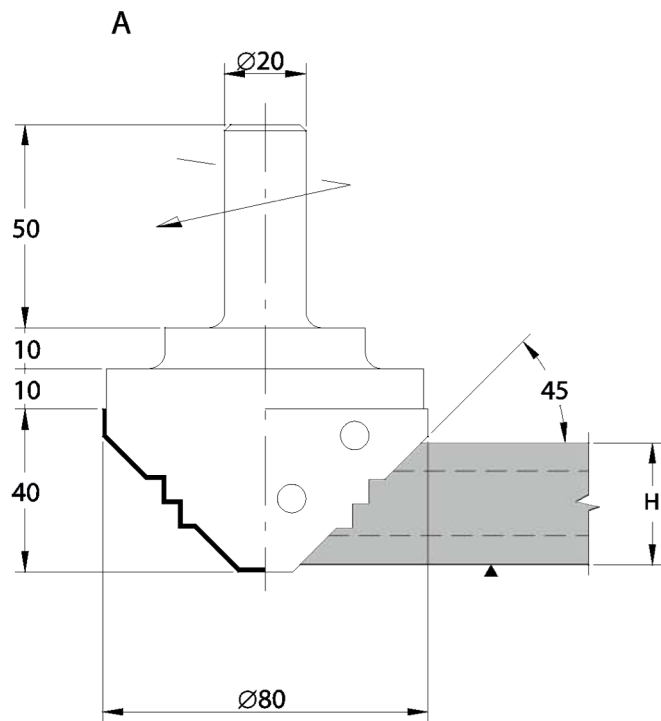

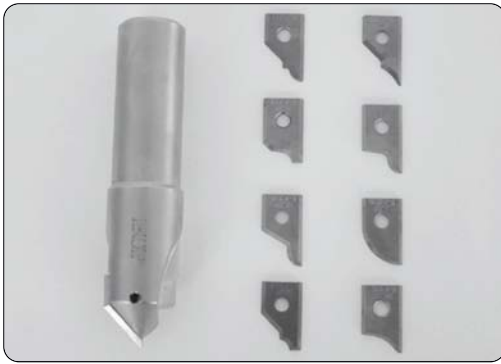

**APPLICATION:**

Production of profile for kitchen doors or bath furnitures.

**MACHINE:**

CNC router.

**TECHNICAL INFORMATION:**

Manufactured with indexable micrograin solid carbide knives. Suitable for MDF panels. The cutter can work with any of the 9 profiles suggested. Supplied with cylindrical shank d. 20x50. Increase of 15% for tapered shanks.

**MEC HW Z=1**

Spare Parts

Code	D	S	Z	Rpm Max	Price Code
5019.000.001	24	25	1	20.000	B19

Profile	knife	Screw	Key
A	8170.025.012	8330.035.003	8345.015.000
B	8170.025.012		
C	8170.025.012		
D	8170.025.012		
E	8170.025.012		
F	8170.025.012		
G	8170.025.012		
H	8170.025.012		
I	8170.025.012		

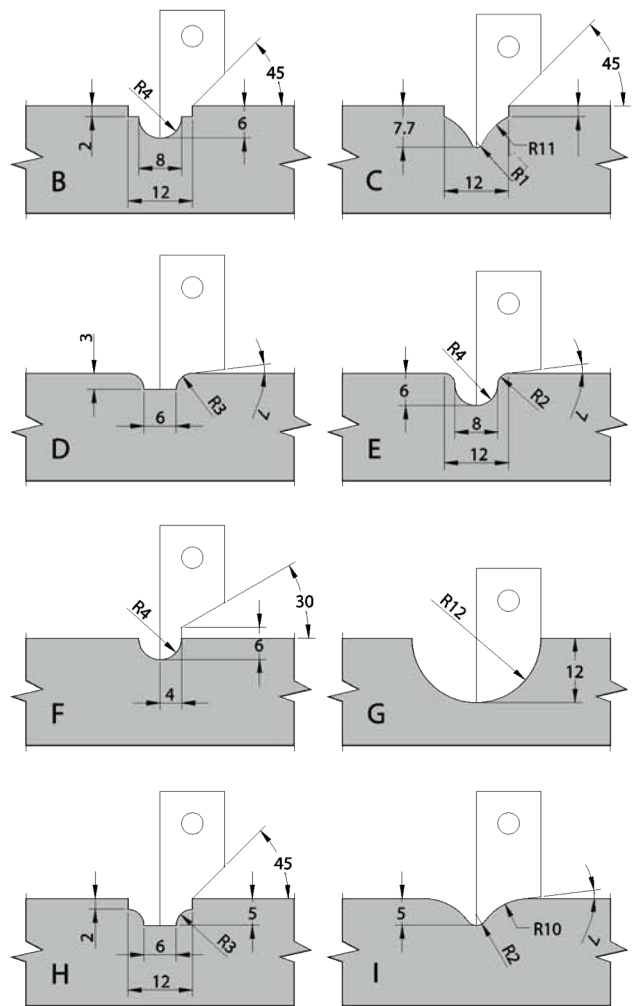
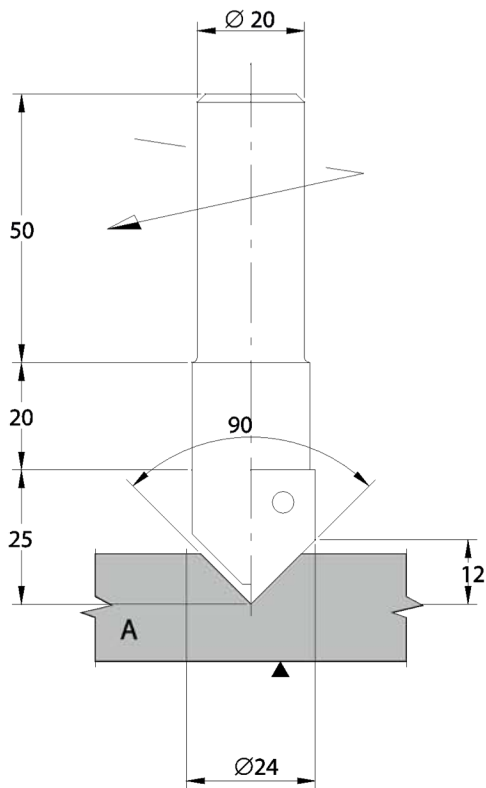



**APPLICATION:**

Production of window grill jointing.

**MACHINE:**

Stegherr.

**TECHNICAL INFORMATION:**

Manufactured with indexable micrograin solid carbide knives. Produced with suitable cutting angles for different types of wood. In the order please state: cutter "A", required profile and material to be worked; cutter "B", small diameter "d". Supplied with M12x1 threaded shank for Stegherr machines.

**MEC HW Z=2**

Code	D	S	d	Rpm Max	Price Code	Profile	Spare Parts		
							Knife	Screw	Key
5020.000.001	40	20		20.000	E22	A	8170.020.020	8330.035.003	8345.015.000
5020.000.002	40	25		20.000	M22	A	8170.025.020	8330.035.003	8345.015.000
5020.000.003	50	20		20.000	M22	A	8170.020.025	8330.035.003	8345.015.000
5020.000.004	50	25		20.000	D23	A	8170.025.025	8330.035.003	8345.015.000
5020.000.005	50	30		20.000	L23	A	8170.030.025	8330.035.003	8345.015.000
5020.000.006	60	30		20.000	B24	A	8170.030.030	8330.035.003	8345.015.000
5020.004.000	46,4	43	4	20.000	L21	B	8145.300.012/8105.200.012	8330.035.004	8345.015.000
5020.005.000	47,4	42,5	5	20.000	L21	B	8145.300.012/8105.200.012	8330.035.004	8345.015.000
5020.007.000	49,4	41,5	7	20.000	L21	B	8145.300.012/8105.200.012	8330.035.004	8345.015.000
5020.009.000	51,4	40,5	9	20.000	L21	B	8145.300.012/8105.200.012	8330.035.004	8345.015.000
5020.011.000	53,4	39,5	11	20.000	L21	B	8145.300.012/8105.200.012	8330.035.004	8345.015.000
5020.013.000	55,4	38,5	13	20.000	L21	B	8145.300.012/8105.200.012	8330.035.004	8345.015.000

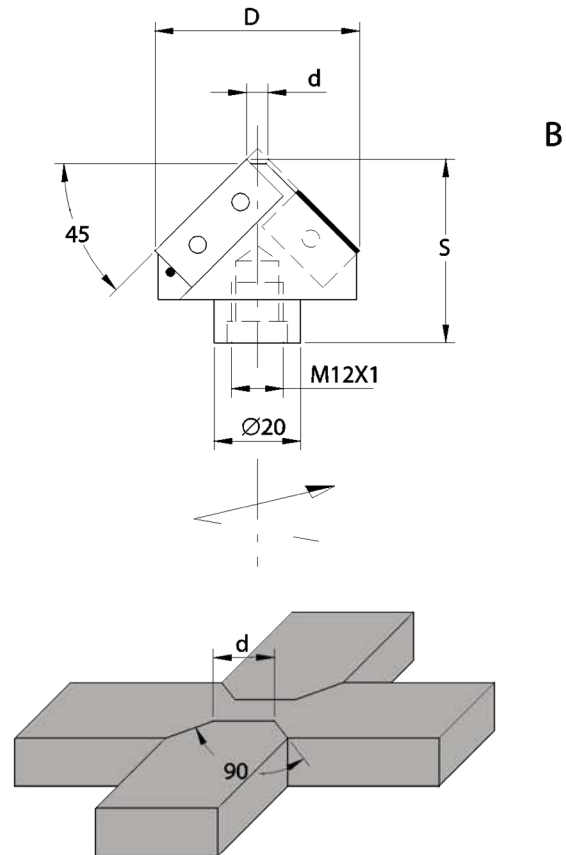
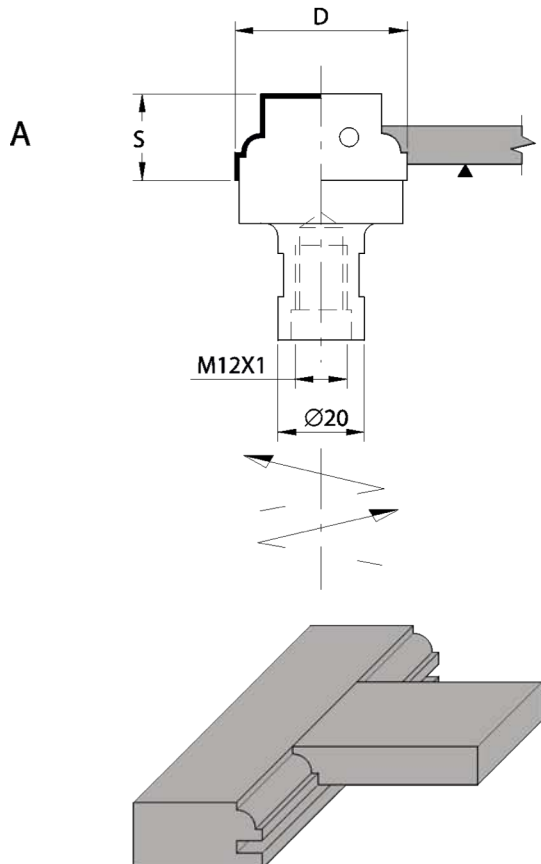





**APPLICATION:**  
Profiling of solid wood doors.

**MACHINE:**  
CNC router.

**TECHNICAL INFORMATION:**  
Manufactured with indexable micrograin solid carbide knives. Produced with suitable cutting angles for solid wood. The cutter can work with different profile knives to obtain suggested profiles on various wood thickness. Cutter body made by "Ergal" light alloy. Supplied with cylindrical shank d. 20x50 or d. 25x55.

**MEC HW Z=2**

Profile cutter spare parts

Code	D	S	Rpm Max	Price Code	Profile	Knife	Screw	Wedge	Key
5021.000.001	100	63,5	12.000	H33	A	8170.025.030	8285.008.000	8280.210.000	8350.040.000
					B	8170.025.030			
					C	8170.025.030			
					D	8170.025.030			

Straight cutter spare parts

Knife	Screw	Wedge	Spur	Spur screw	45° insert
8105.400.012	8285.008.000	8280.360.000	8120.140.002	8295.005.000	8130.220.045

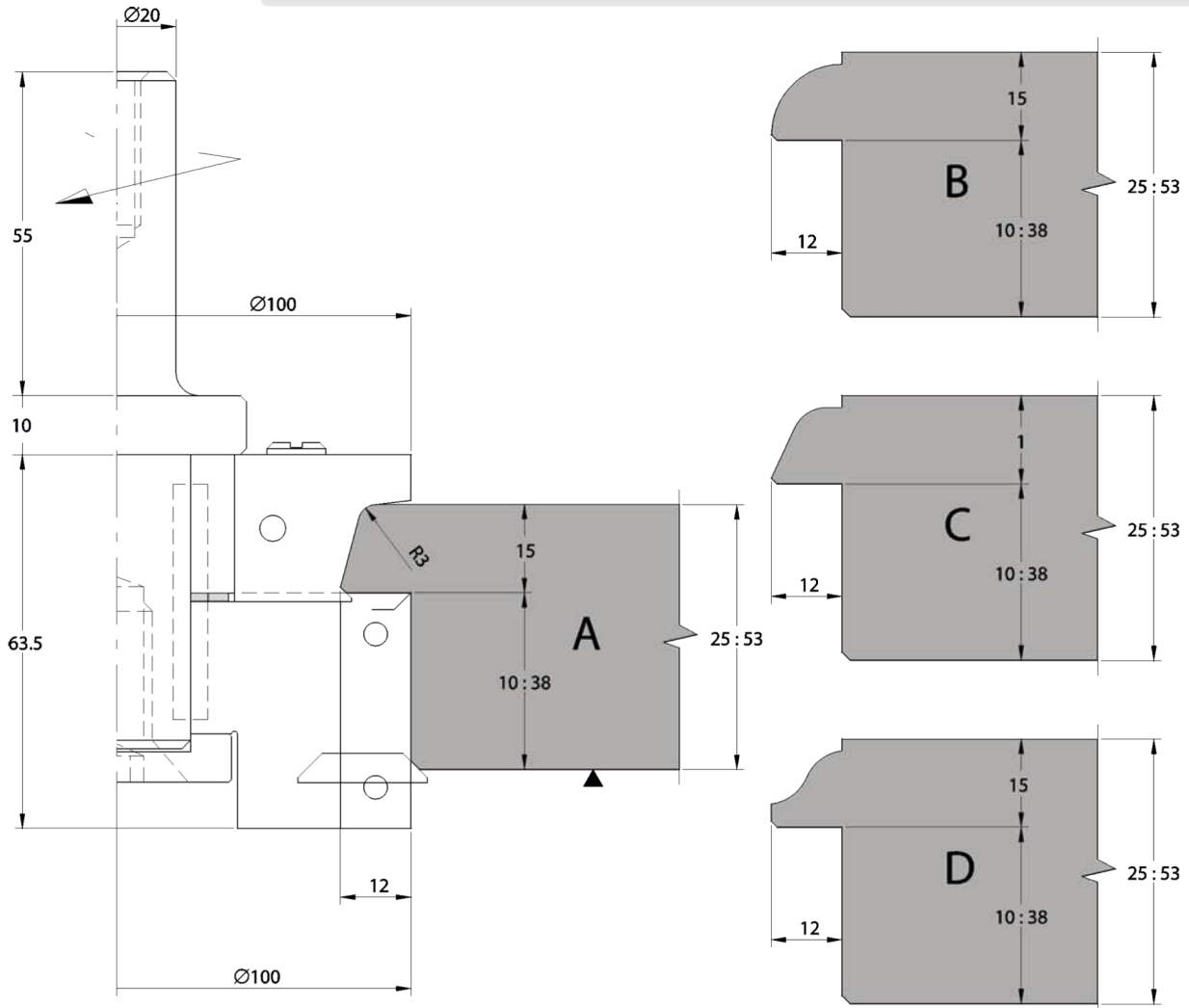



**APPLICATION:**

Profiling of solid wood doors with variable thickness.

**MACHINE:**

CNC router.

**TECHNICAL INFORMATION:**

Manufactured with indexable micrograin solid carbide knives. Produced with suitable cutting angles for solid wood. The cutter can work with different profile knives to obtain suggested profiles on various wood thickness. Cutter body made by "Ergal" light alloy. Supplied with cylindrical shank d. 20x50 or d. 25x55.

**MEC HW Z=2**

Spare Parts

Code	D	S	Rpm Max	Price Code	Profile	Knife	Wedge	Screw	Spur	Screw	Key
5022.130.001	130	66	12.000	H35	A	8170.025.035-A1	8280.210.000	8285.008.000			8350.040.000
						8170.025.035-A2	8280.210.000	8285.008.000			8350.040.000
						8105.076.012-A3	8280.070.000	8285.006.000	8120.140.002	8295.005.000	8350.030.000
5022.130.002	130	66	12.000	H35	B	8170.025.030-B1	8280.210.000	8285.008.000			8350.040.000
						8170.025.030-B2	8280.210.000	8285.008.000			8350.040.000
						8105.150.012-B3	8280.130.000	8285.008.000			8350.040.000

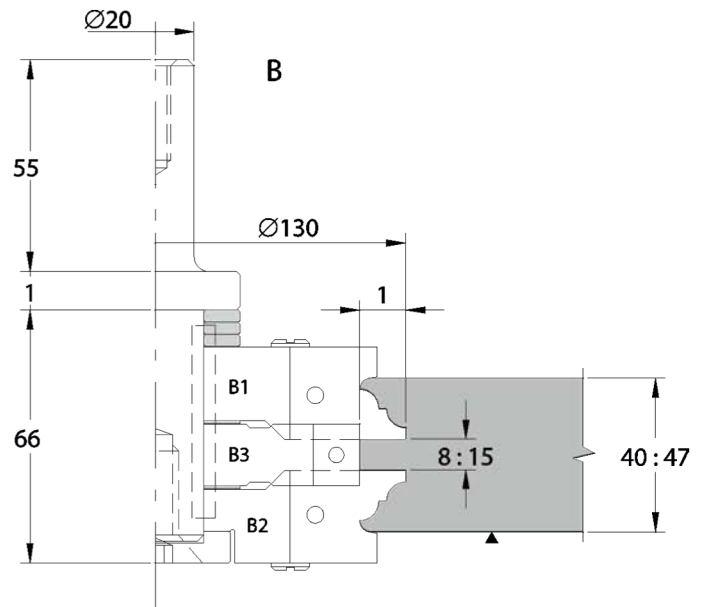
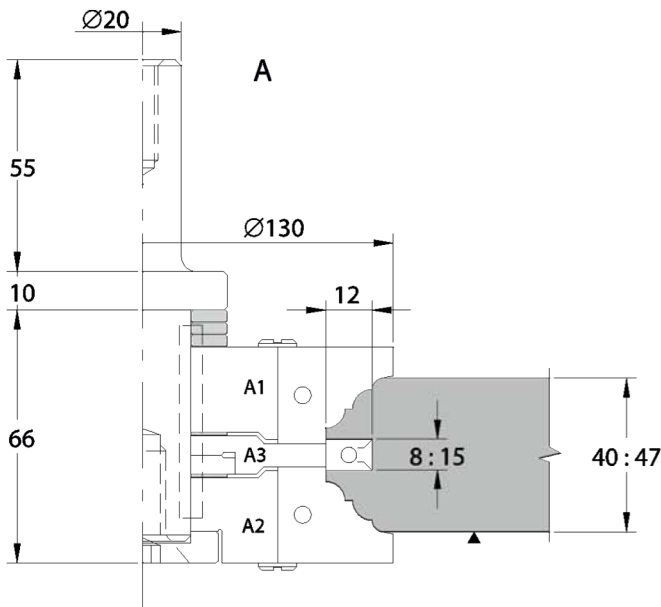

PROFILE SAMPLES

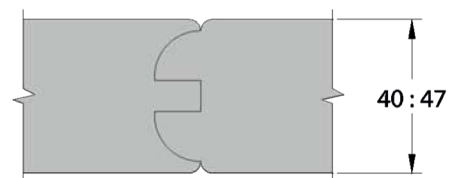
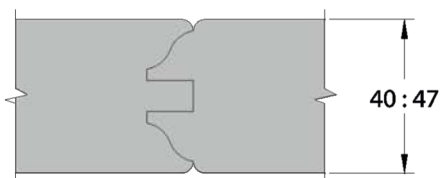
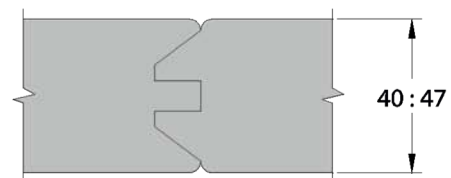
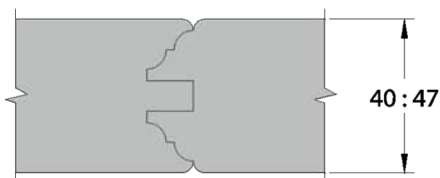



**APPLICATION:**

Production of a complete solid wood door.

**MACHINE:**

CNC router.

**TECHNICAL INFORMATION:**

Manufactured with indexable micrograin solid carbide knives. Door profile with recovering of glass stop bar. Suitable cutting angles for solid wood. Cutter body made by "Ergal" light alloy. Supplied on cutter spindle D. 30 with specific shank suitable for different types of electrospindles (HSK, ISO 30, ISO 40...). Price of cutterset does not include cutter spindles.

**MEC HW**

Spare Parts

Code	D	Z	Profilo	Rpm Max	Price Code	Knife	Knife	Knife	Spur	Knife
5023.000.001	130	2	A	10.000	D32	8170.025.025-A1	8105.400.012-A2		8120.140.002	8130.220.020
5023.000.002	150	3	B	9.000	E34	8170.050.030-B1	8170.050.030-B2			
5023.000.003	130	2	C	10.000	H36	8170.030.035-C1	8170.030.030-C2	8105.076.012-C3	8120.140.002	8130.220.020
5023.000.004	130	2	D	10.000	C35	8170.030.030-D1	8105.300.012-D2	8105.120.012-D3	8120.140.002	8130.220.020

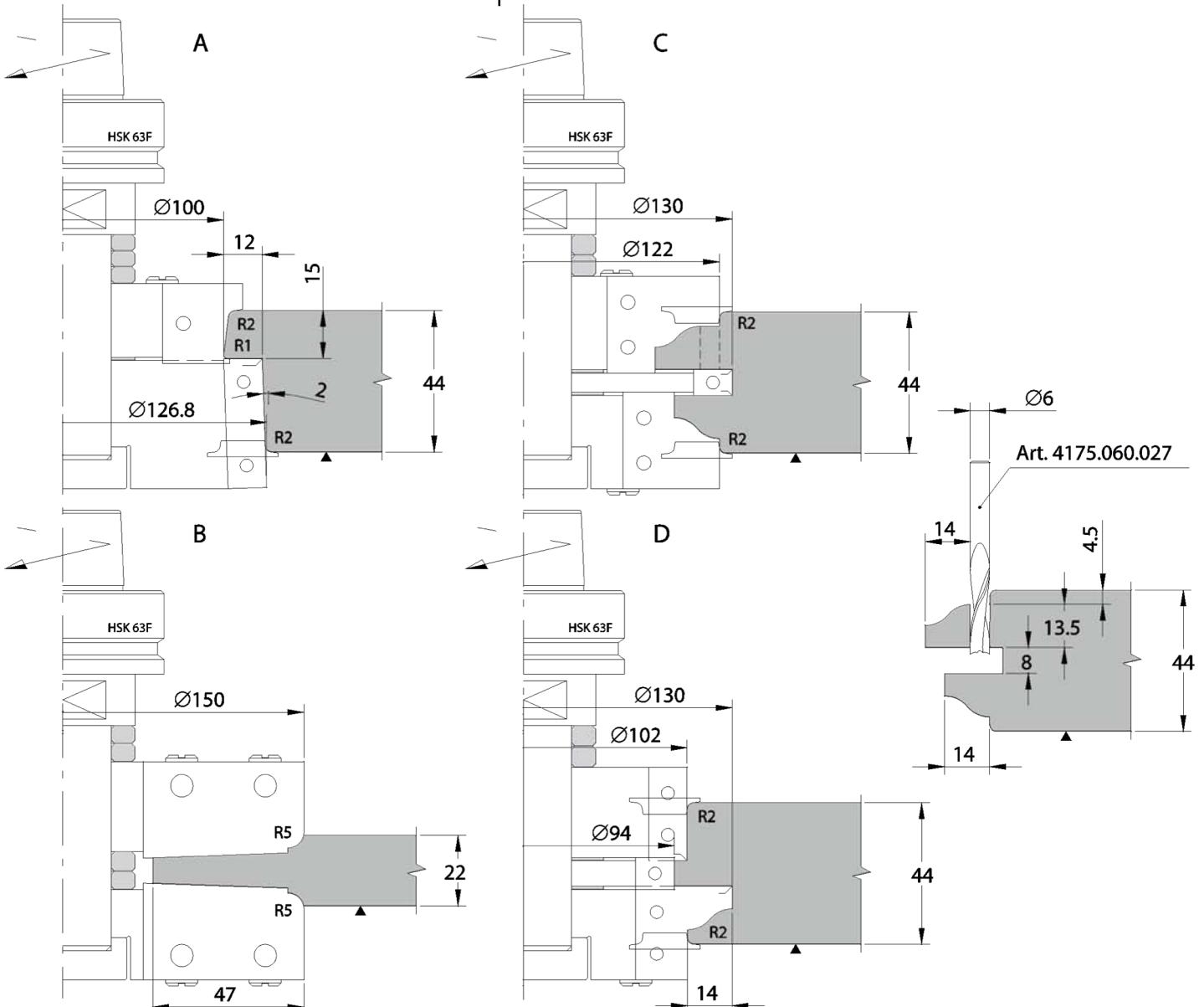



**APPLICATION:**

Production of several profiles.

**MACHINE:**

CNC router.

**TECHNICAL INFORMATION:**

Manufactured with indexable micrograin solid carbide knives and HSS profiled supports. Supplied without knives and supports with cylindrical shank d. 20x50. Increase of 15% for tapered shanks.

**MEC HW Z=2**

Spare Parts

Code	D	S	P max	Rpm Max	Price Code	Knife	Back plate	Wedge	Screw	Key
5025.080.001	80	40	10	12.000	F22	8170.040.030	8265.040.030	8270.360.000	8285.008.000	8350.040.000
5025.080.002	80	60	10	12.000	D23	8170.060.030	8265.060.030	8270.560.000	8285.008.000	8350.040.000
5025.090.001	90	40	15	10.000	F22	8170.040.035	8265.040.035	8270.360.000	8285.008.000	8350.040.000
5025.090.002	90	60	15	10.000	D23	8170.060.035	8265.060.035	8270.560.000	8285.008.000	8350.040.000

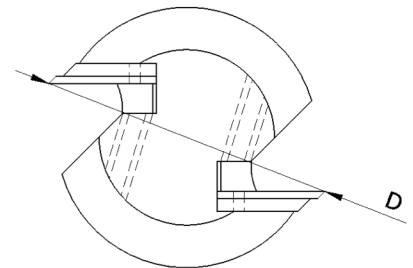
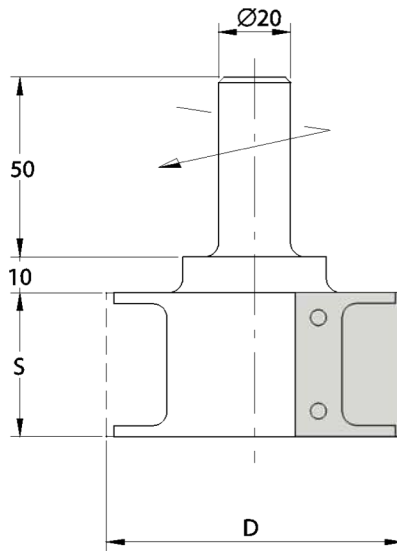

**HOW TO CALCULATE THE PRICE FOR COMPLETE CUTTER**

Profile to realize: P=10 H=35

N° 1 Art. 5025.080.001 + N°2 Art. 8170.040.030  
+ N° 2 Art. 8265.040.030

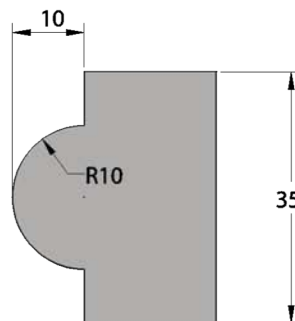



**APPLICATION:**

Production of different profiles on request.

**MACHINE:**

CNC router.

**TECHNICAL INFORMATION:**

Manufactured with indexable micrograin solid carbide knives. Produced with only one cut to obtain small diameters. With suitable cutting angle for different types of wood. Supplied with cylindrical shank d. 20x50 or d.25x55. Increase of 15% for tapered shanks.

**MEC HW Z=1**

Code	D	S	Rpm Max	Price Code	Spare Parts		
					Knife	Screw	Key
5030.024.020	24	20	20.000	L19	8170.020.012	8330.035.003	8345.015.000
5030.024.025	24	25	20.000	M19	8170.025.012	8330.035.003	8345.015.000
5030.030.020	30	20	20.000	C20	8170.015.020	8330.035.003	8345.015.000
5030.030.025	30	25	20.000	D20	8170.015.025	8330.035.003	8345.015.000
5030.030.030	30	30	20.000	F20	8170.015.030	8330.035.003	8345.015.000
5030.040.020	40	20	18.000	F20	8170.020.020	8330.035.003	8345.015.000
5030.040.025	40	25	18.000	H20	8170.020.025	8330.035.003	8345.015.000
5030.040.030	40	30	18.000	L20	8170.020.030	8330.035.003	8345.015.000
5030.040.035	40	35	18.000	F21	8170.020.035	8330.035.003	8345.015.000

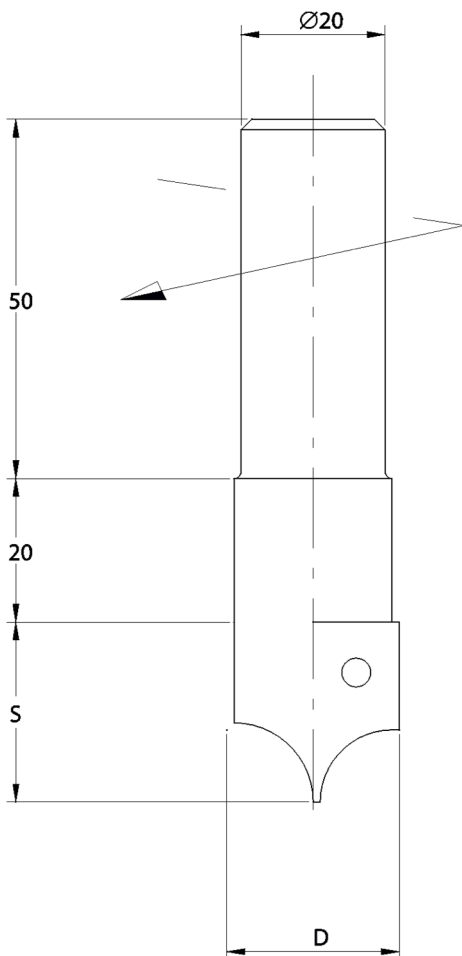

PROFILE SAMPLE

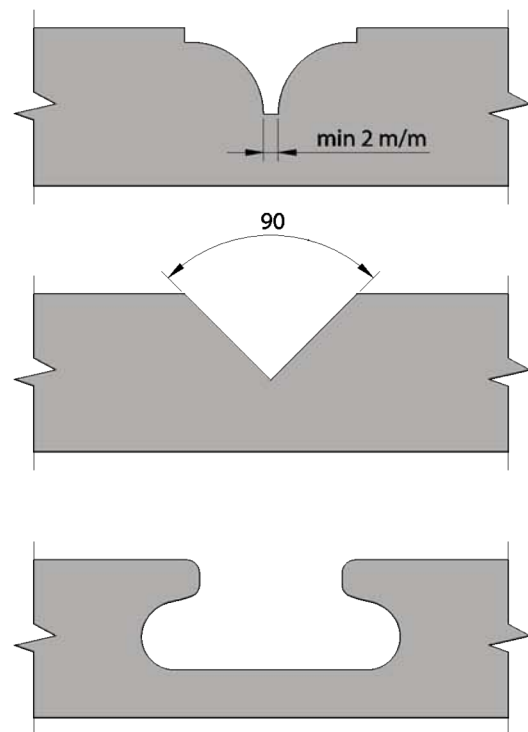



**APPLICATION:**

To produce raised panels profiles.

**MACHINE:**

CNC router.

**TECHNICAL INFORMATION:**

Manufactured with indexable micrograin solid carbide knives. Produced with suitable cutting angles for different types of wood. Supplied with cylindrical shank d. 20x50 or d. 25x55. Increase of 15% for tapered shanks.

**MEC HW**

**Art. 5035**

Code	D	S	Z	Rpm Max	Price Code	Code	D	S	Z	Rpm Max	Price Code
5035.080.020	80	20	2	18.000	C26	5035.100.035	100	35	2	14.000	A28
5035.080.025	80	25	2	18.000	H26	5035.120.030	120	30	2	12.000	H27
5035.080.030	80	30	2	16.000	C27	5035.120.035	120	35	2	10.000	D28
5035.100.025	100	25	2	14.000	L26	5035.140.030	140	30	2	9.000	C28
5035.100.030	100	30	2	14.000	E27	5035.140.035	140	35	2	9.000	L28

**Art. 5040**

Code	D	S	Z	Price Code
5040.030.012	30	12	3	E16

Spare Parts

Knife	Screw	Key
8105.120.012	8330.035.002	8345.015.000

Spare Parts

Article **5035**

knife	8170
Screw	8330
Key	8345-8350

ESEMPI DI PROFILI / PROFILE SAMPLE

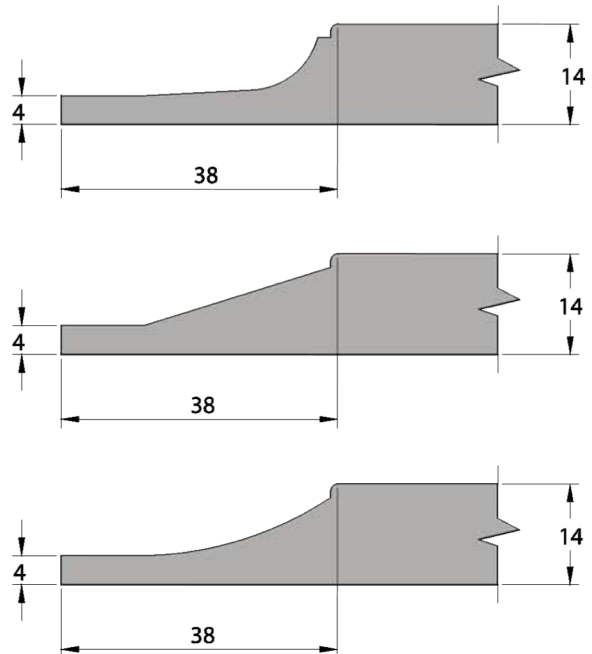
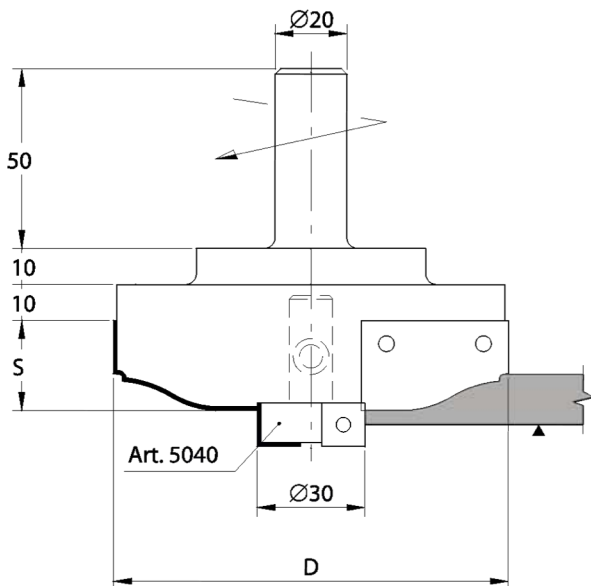



**APPLICATION:**  
Panel profiling with 30° - 45° - 60° bevel.

**MACHINE:**  
CNC router.

**TECHNICAL INFORMATION:**  
Manufactured with indexable micrograin solid carbide knives. Produced with suitable cutting angles for different types of wood. Supplied with cylindrical shank d. 20x50 or d. 25x55. Increase of 15% for tapered shanks.

**MEC HW Z=2**

Code	D	S	$\alpha$	Rpm Max	Price Code	H Max	Spare Parts		
							Knife	Screw	Key
5045.000.001	60	35	60°	18.000	H21	23	8105.300.012	8330.035.004	8345.015.000
5045.000.002	60	35	45°	18.000	B22	19	8105.300.012	8330.035.004	8345.015.000
5045.000.003	70	30	30°	18.000	F22	13	8105.300.012	8330.035.004	8345.015.000
5045.000.004	70	55	60°	14.000	F23	40	8105.500.012	8330.035.004	8345.015.000
5045.000.005	90	50	45°	14.000	B24	33	8105.500.012	8330.035.004	8345.015.000
5045.000.006	100	40	30°	12.000	H24	23	8105.500.012	8330.035.004	8345.015.000
5045.000.007	110	60	45°	12.000	A26	40	8105.600.012	8330.035.004	8345.015.000

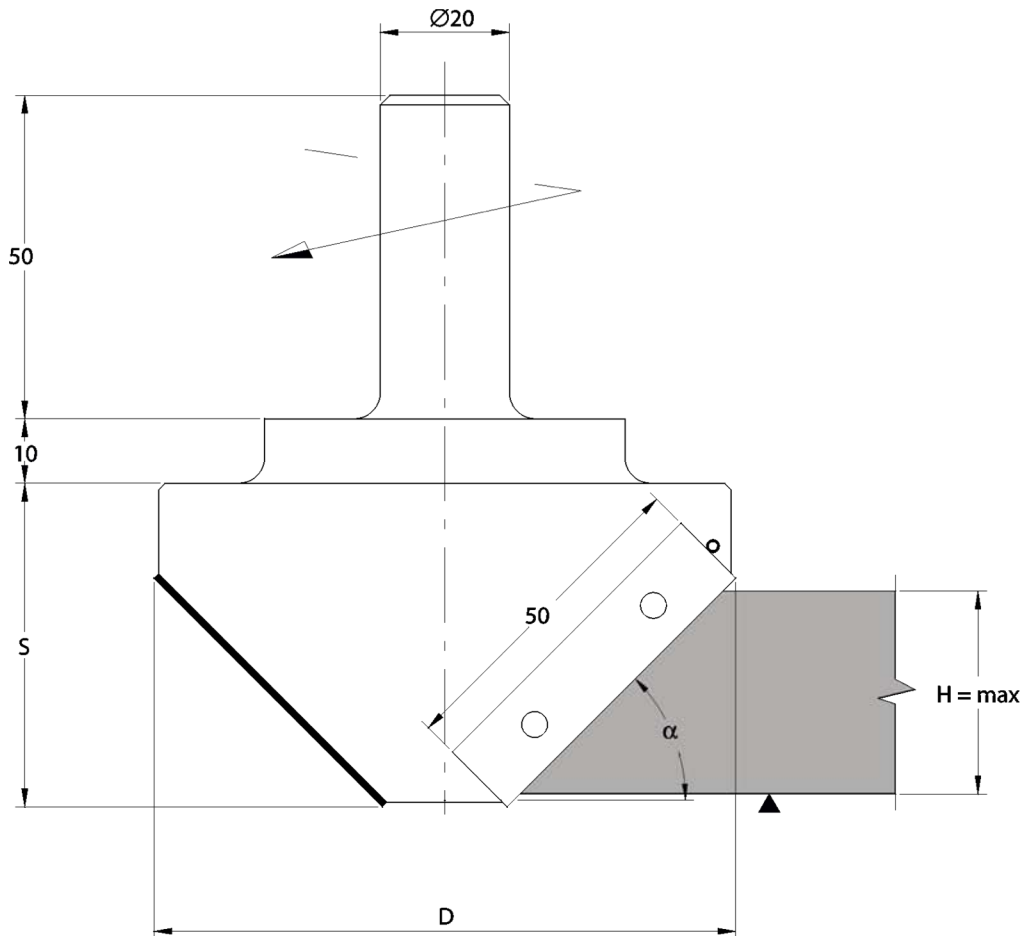



**APPLICATION:**

90° profiles and "V-GROOVE" application for foulding system.

**MACHINE:**

CNC router.

**TECHNICAL INFORMATION:**

Manufactured with indexable micrograin solid carbide knives. Produced with suitable cutting angles for different types of wood. Supplied with cylindrical shank d. 20x50. Increase of 15% for tapered shanks.

**MEC HW Z=1+1**

Code	D	S	Rpm Max	Price Code	Profile	Spare Parts		
						Knife	Screw	Key
5046.000.001	48	35	18.000	D23	A	8163.300.012	8330.035.004	8345.015.000
						8105.200.012	8330.035.004	8345.015.000
5046.000.002	60	40	18.000	D24	B	8163.400.012	8330.035.004	8345.015.000
						8105.300.012	8330.035.004	8345.015.000
5046.000.003	75	50	14.000	C26	C	8163.500.012	8330.035.004	8345.015.000
						8105.400.012	8330.035.004	8345.015.000

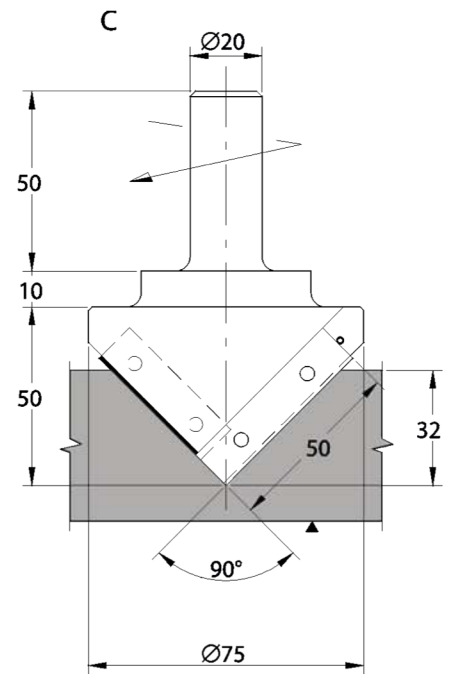
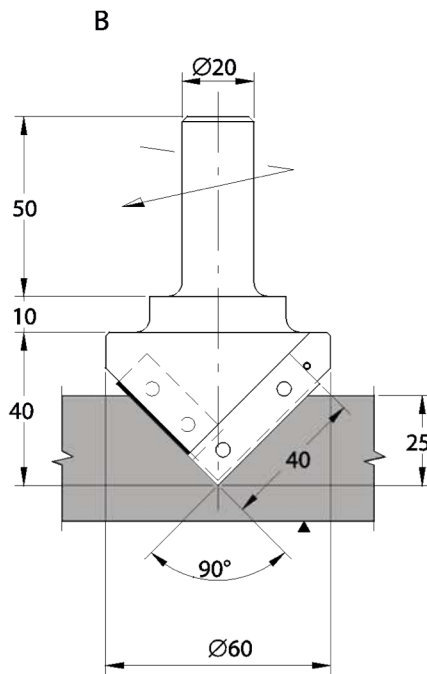
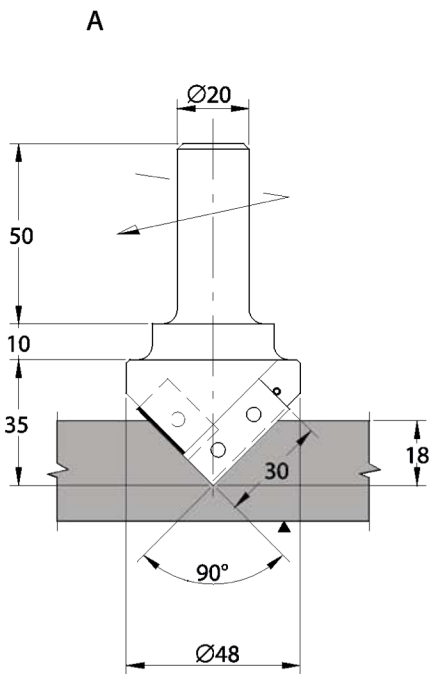





**APPLICATION:**  
Panel profiling with adjustable angles.

**MACHINE:**  
CNC router.

**TECHNICAL INFORMATION:**  
Manufactured with indexable micrograin solid carbide knives.  
Top angle adjustment: 0°-45; bottom angle adjustment 0°-90°.  
Supplied with d. 20x50 or d. 25x55 cylindrical shank.

**MEC HW Z=2**

Code	D	D max	S	d	Rpm max	Price Code	Spare Parts
							Knife
5048.100.001	85	102	40	20	14.000	H34	8162.400.012
5048.100.002	85	102	40	25	14.000	H34	8162.400.012

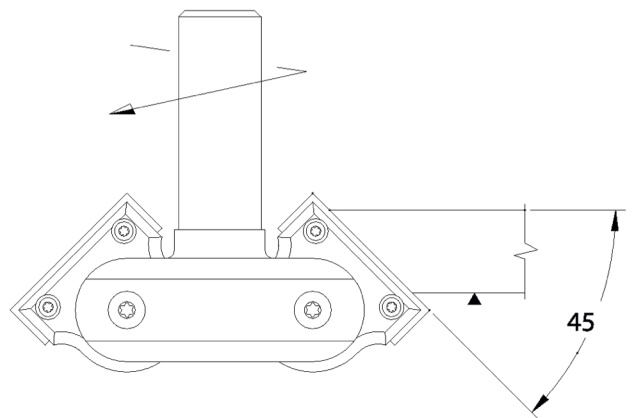
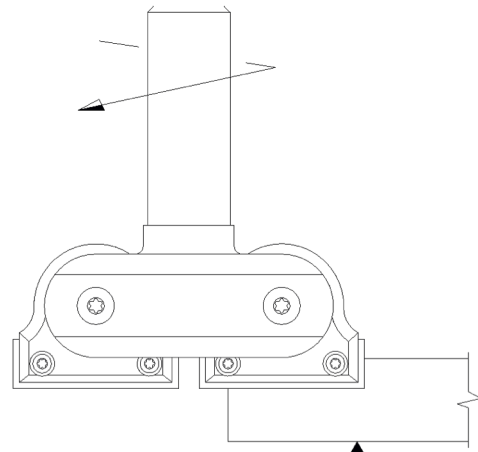
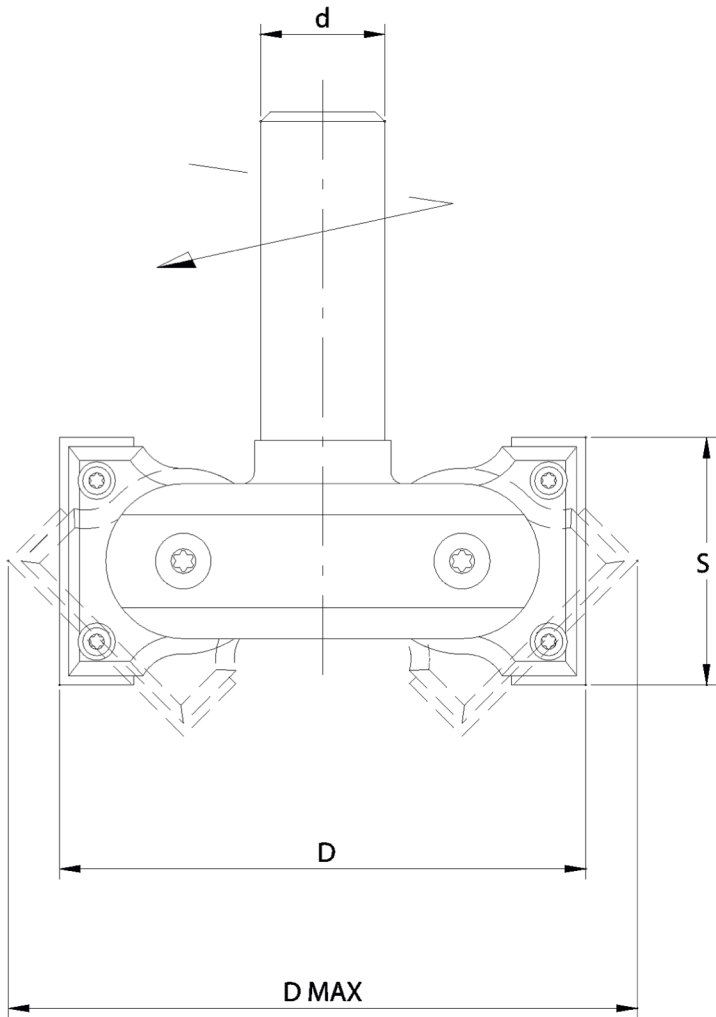



**APPLICATION:**  
Handrails profilig.

**MACHINE:**  
CNC router, 5 axis CNC router.

**TECHNICAL INFORMATION:**  
Manufactured with indexable micrograin solid carbide knives.  
Produced with opposite shear angle and divided cut suitable for different types of wood. We produce special profiles on drawing.  
Supplied with cylindrical shank d. 25x55.

**MEC HW Z=2+2**

Code	D	D1	S	LT	Rpm max	Profile	Price Code	Spare Parts	
								Knife	Screw
5049.000.001	94	50	60	150	16.000	A	H32	8170.030.025 A1	8330.035.003
								8170.035.035 A2	8330.035.003
5049.000.002	120	50	77	150	12.000	B	H34	8170.040.025 B1	8330.035.003
								8175.050.040 B2	8330.035.003
5049.000.003	115	35	64	140	14.000	C	A35	8170.030.025 C1	8330.035.003
								8175.060.050 C2	8330.035.003
5049.000.004	115	35	66	140	14.000	D	A35	8170.025.020 D1	8330.035.003
								8175.060.050 D2	8330.035.003

PROFILE SAMPLES

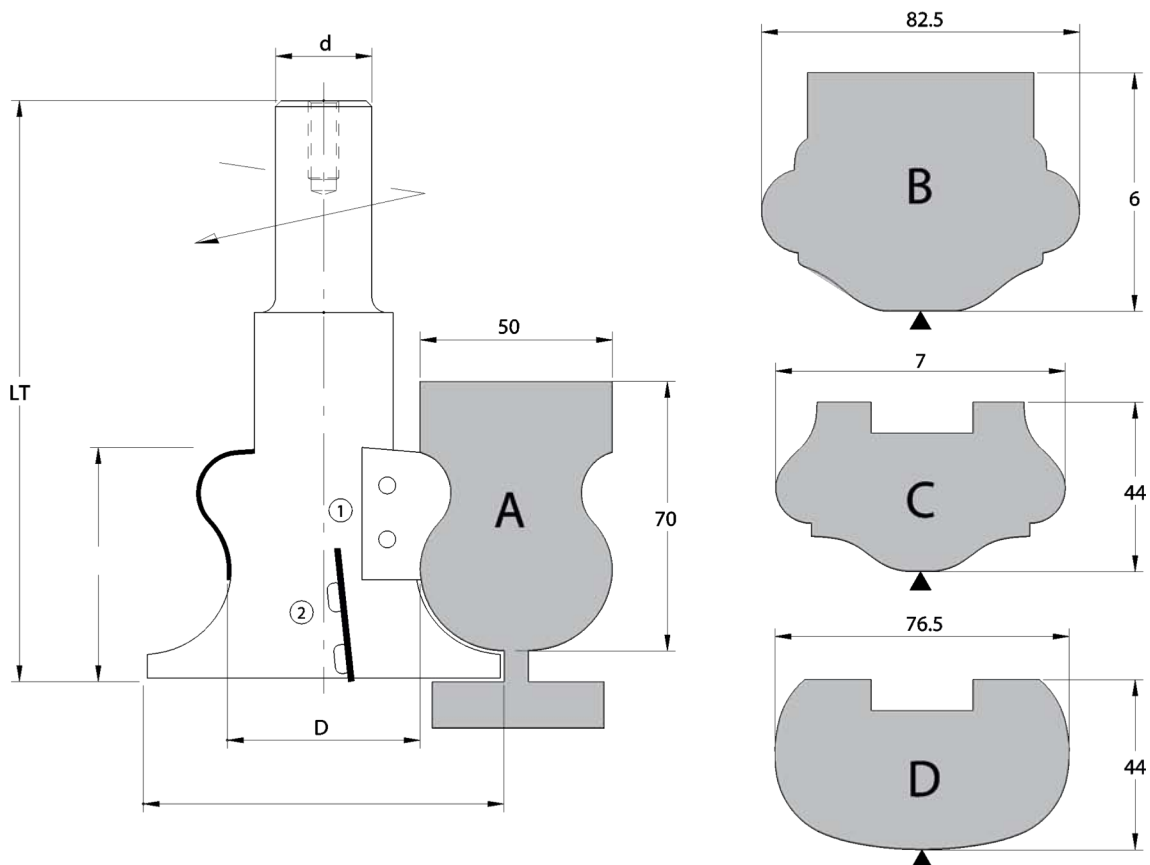



**APPLICATION:**

Jointing and rabbeting of panels.

**MACHINE:**

CNC router.

**TECHNICAL INFORMATION:**

Manufactured with indexable micrograin solid carbide knives. Produced with suitable cutting angles for different types of wood. In the order please state the material to be worked. Supplied with cylindrical shank d. 20x50 or d. 25x55. Increase of 15% for tapered shanks.

**MEC HW**

Code	D	S	Z	Rpm Max	Price Code	Spare Parts				
						Knife	Screw	Spur	Screw	Key
5050.050.030	50	30	2	18.000	M19	8105.300.012	8330.035.004			8345.015.000
5050.050.050	50	50	2	18.000	M20	8105.500.012	8330.035.004			8345.015.000
5050.050.060	50	60	2	16.000	G21	8105.600.012	8330.035.004			8345.015.000
5050.050.080	50	80	2	14.000	F22	8105.800.012	8330.035.004			8345.015.000
5050.060.030	60	30	2	18.000	E20	8105.300.012	8330.035.004			8345.015.000
5050.060.050	60	50	2	16.000	D21	8105.500.012	8330.035.004			8345.015.000
5050.060.060	60	60	2	16.000	A22	8105.600.012	8330.035.004			8345.015.000
5050.060.080	60	80	2	14.000	B23	8105.800.012	8330.035.004			8345.015.000
5055.050.030	50	30	2+2	18.000	F21	8105.300.012	8330.035.004	8120.140.002	8295.005.000	8345.015.000
5055.050.050	50	50	2+2	18.000	E22	8105.500.012	8330.035.004	8120.140.002	8295.005.000	8345.015.000
5055.050.060	50	60	2+2	16.000	D23	8105.600.012	8330.035.004	8120.140.002	8295.005.000	8345.015.000
5055.050.080	50	80	2+2	14.000	C24	8105.800.012	8330.035.004	8120.140.002	8295.005.000	8345.015.000
5055.060.030	60	30	2+2	18.000	M21	8105.300.012	8330.035.004	8120.140.002	8295.005.000	8345.015.000
5055.060.050	60	50	2+2	16.000	L22	8105.500.012	8330.035.004	8120.140.002	8295.005.000	8345.015.000
5055.060.060	60	60	2+2	16.000	H23	8105.600.012	8330.035.004	8120.140.002	8295.005.000	8345.015.000
5055.060.080	60	80	2+2	14.000	G24	8105.800.012	8330.035.004	8120.140.002	8295.005.000	8345.015.000

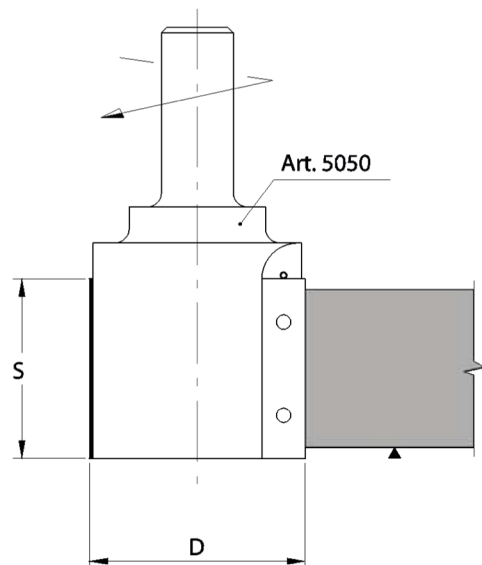
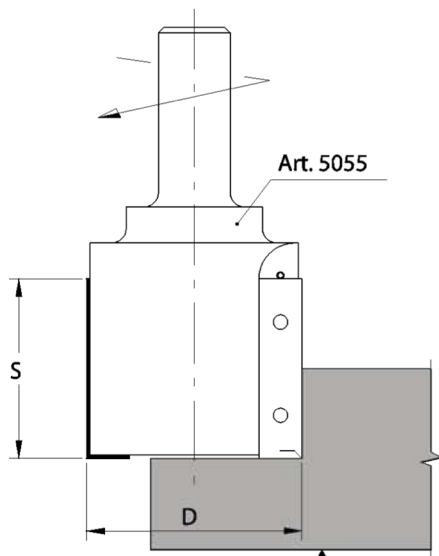



**APPLICATION:**

Surfacing and rabbeting of panels.

**MACHINE:**

CNC router.

**TECHNICAL INFORMATION:**

Manufactured with indexable micrograin solid carbide knives. Produced with suitable cutting angles for different types of wood. In the order please state the material to be worked. Supplied with cylindrical shank d. 20x50.

**MEC HW Z=3**

Code	D	S	Rpm Max	Price Code	Spare Parts		
					Knife	Screw	Key
5060.080.012	80	12	16.000	H23	8105.120.012	8330.035.004	8345.015.000
5060.080.020	80	20	16.000	B24	8145.200.012	8330.035.004	8345.015.000
5060.100.012	100	12	14.000	B24	8105.120.012	8330.035.004	8345.015.000
5060.100.020	100	20	14.000	F24	8145.200.012	8330.035.004	8345.015.000

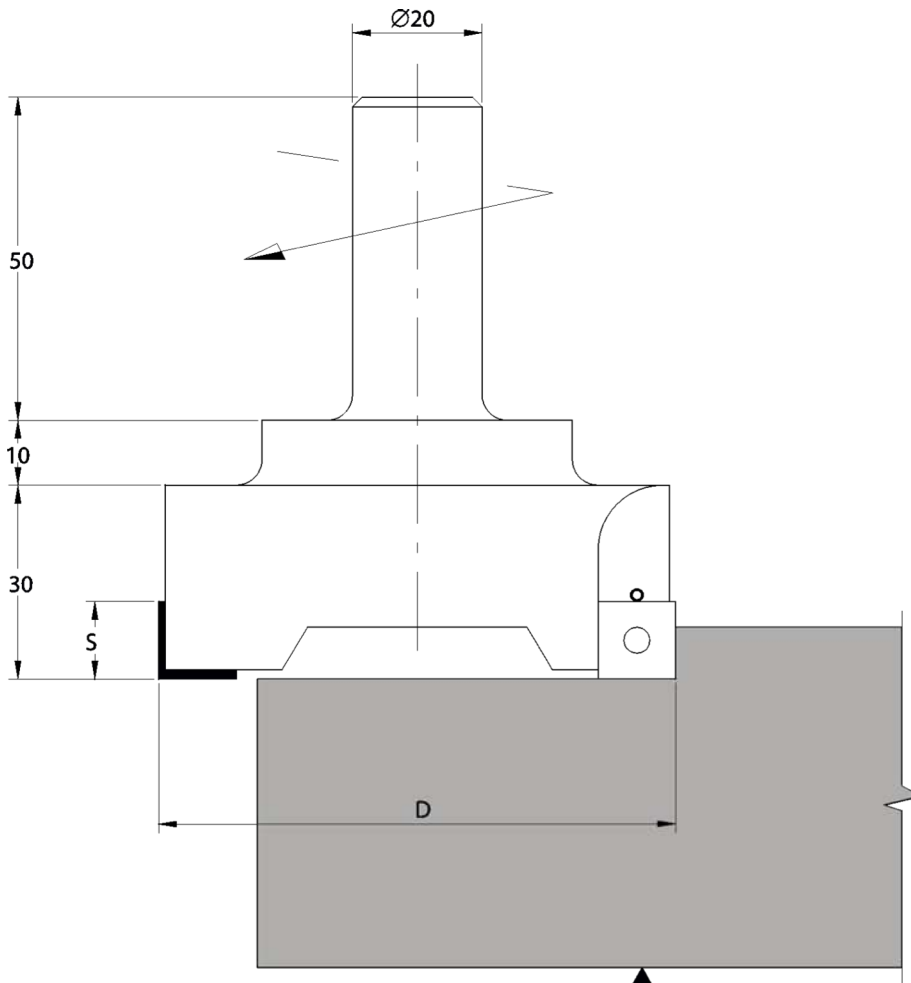



**APPLICATION:**

Surfacing tools for router tables.

**MACHINE:**

CNC router.

**TECHNICAL INFORMATION:**

Manufactured with indexable micrograin solid carbide knives. Perfect finishing with radius and shear position of the inserts. Tool body made with "Ergal" light alloy material and mounted on a steel shaft. Supplied with cylindrical shank d. 20x50.

**MEC HW Z=4**

Code	D	D <sub>1</sub>	S	Rpm Max	Price Code	Spare Parts		
						Knife	Screw	Key
5061.110.012	110	100	32	12.000	H27	8180.012.012	8330.035.004	8345.015.000

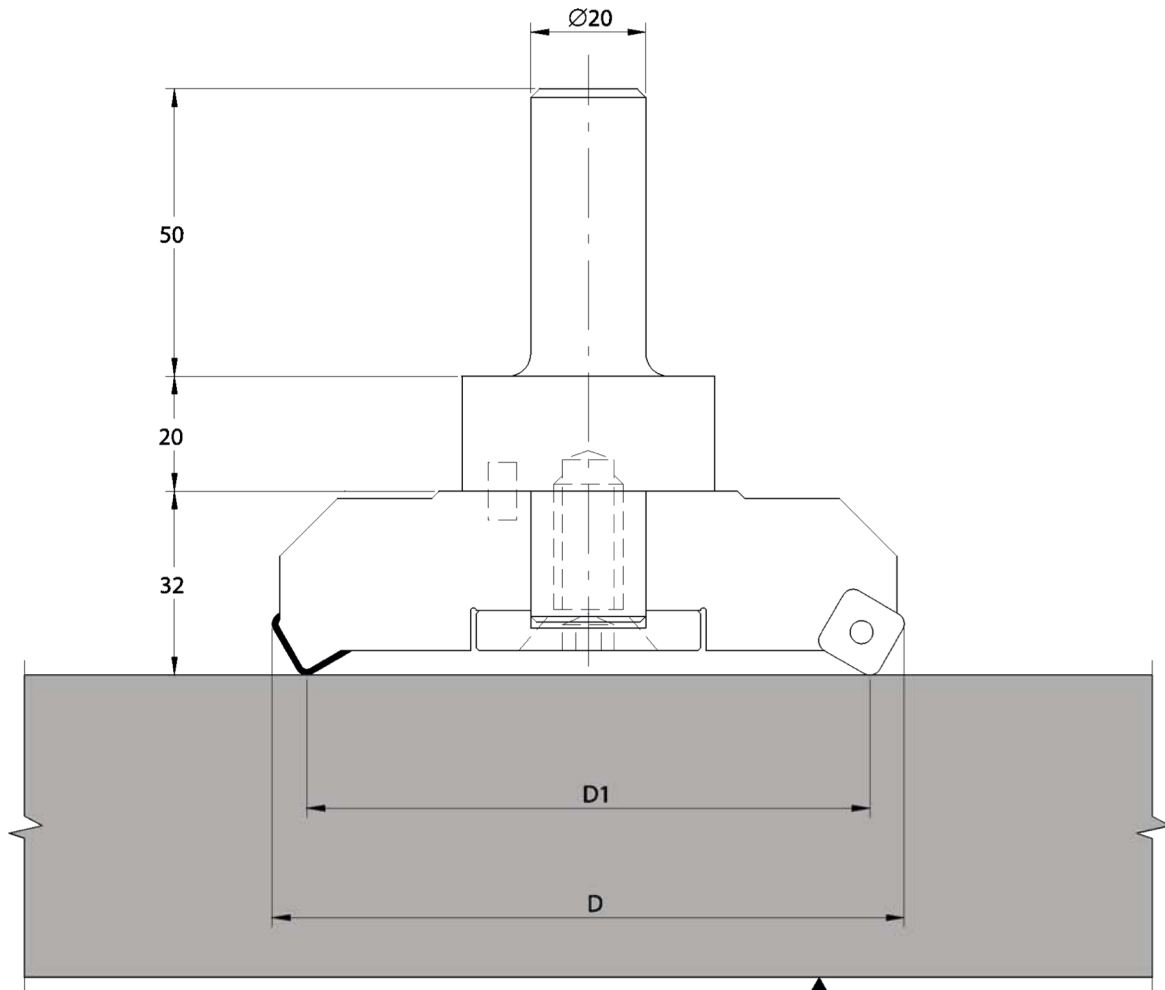



**APPLICATION:**

Surfacing and recessing of MDF kitchen doors.

**MACHINE:**

CNC router.

**TECHNICAL INFORMATION:**

Manufactured with indexable micrograin solid carbide knives. Perfect finishing with excellent chip evacuation. Supplied with cylindrical shank d. 20x50. Increase of 15% for tapered shanks.

**MEC HW Z=2**

Code	D	S	Rpm Max	Price Code	Spare Parts		
					Knife	Screw	Key
5062.058.012	58	12	18.000	D22	8162.300.012	8330.035.004	8345.015.000
5062.078.012	78	12	16.000	H22	8162.400.012	8330.035.004	8345.015.000
5062.098.012	98	12	14.000	C23	8162.500.012	8330.035.004	8345.015.000

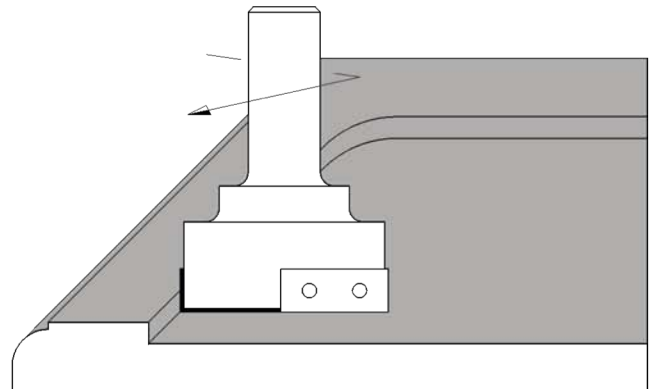
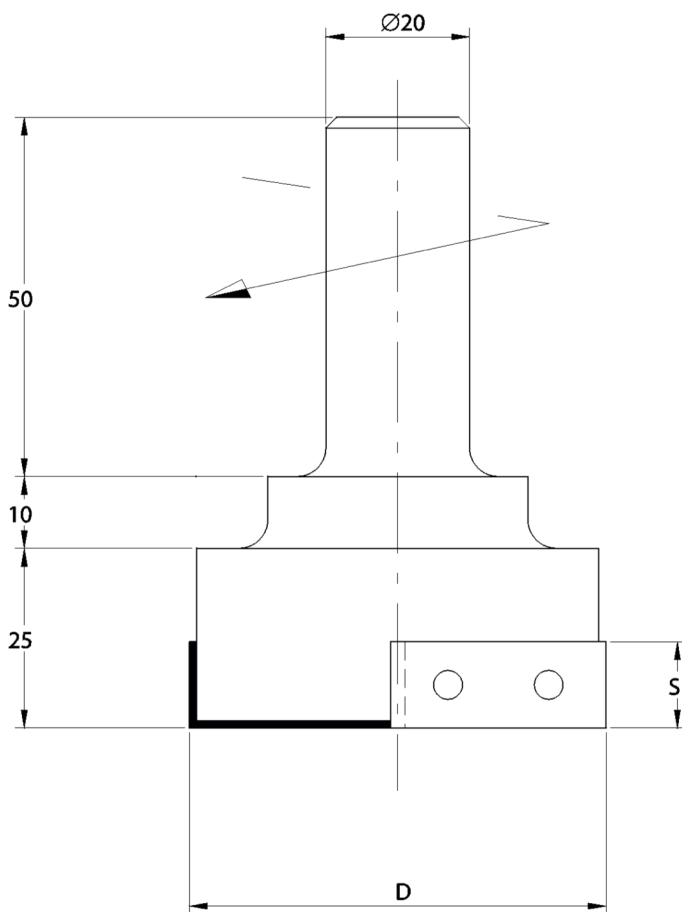



**APPLICATION:**  
Panel sizing and rabbeting.

**MACHINE:**  
CNC router.

**TECHNICAL INFORMATION:**  
Manufactured with indexable micrograin solid carbide knives. If not specified we will supplied the tools with d. 20x50 cylindrical shank and RH rotation. Increase of 15% for tapered shanks.

**MEC HW Z=2**

Code Rh	Code Lh	D	S	Rpm Max	Price Code	Spare Parts			
						Knife Rh	Knife Lh	Screw	Key
5065.020.030	5066.020.030	20	30	20.000	A18	8145.300.012	8146.300.012	8330.035.004	8345.015.000
5065.020.050	5066.020.050	20	50	20.000	E18	8145.500.012	8146.500.012	8330.035.004	8345.015.000

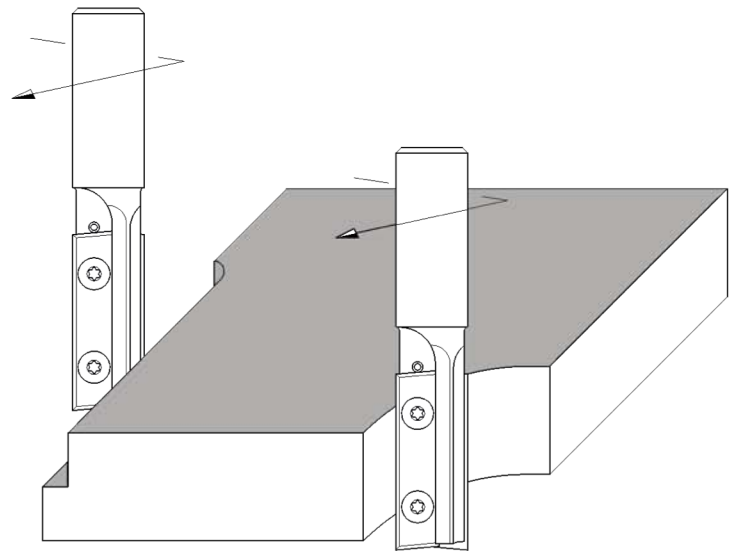
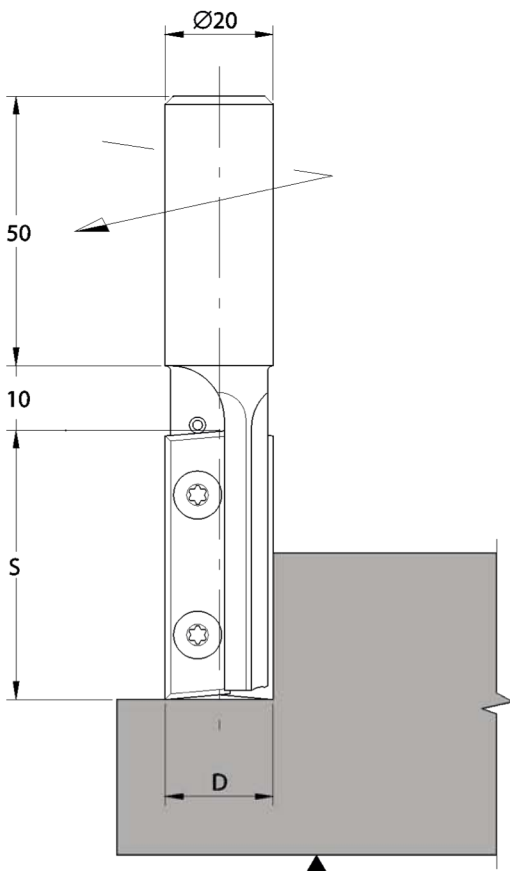



**APPLICATION:**

Panel sizing with plunging capability.

**MACHINE:**

CNC router.

**TECHNICAL INFORMATION:**

Manufactured with indexable micrograin solid carbide knives. The tools has vertical plunging capability. If not specified we will supply the tools with d. 20x50 cylindrical shank and RH rotation. Increase of 15% for tapered shanks.

**MEC HW Z=2+1**

Code Rh	Code Lh	D	S	Rpm Max	Price Code
5070.025.030	5071.025.030	25	30	20.000	L19
5070.025.050	5071.025.050	25	50	18.000	C20
5070.030.030	5071.030.030	30	30	20.000	M19
5070.030.050	5071.030.050	30	50	18.000	D20
5070.030.060	5071.030.060	30	60	16.000	L23
5070.035.030	5071.035.030	35	30	20.000	C23
5070.035.050	5071.035.050	35	50	18.000	E23
5070.035.060	5071.035.060	35	60	16.000	A24
5070.040.030	5071.040.030	40	30	20.000	D23
5070.040.050	5071.040.050	40	50	18.000	G23
5070.040.060	5071.040.060	40	60	16.000	B24

Spare Parts

Knife Rh	Knife Lh	Screw	Knife Rh	Knife Lh
8150.300.009	8151.300.009	8330.035.002	8160.024.010	8161.024.010
8150.500.009	8151.500.009	8330.035.002	8160.024.010	8161.024.010
8145.300.012	8146.300.012	8330.035.004	8160.024.010	8161.024.010
8145.500.012	8146.500.012	8330.035.004	8160.024.010	8161.024.010
8145.600.012	8146.600.012	8330.035.004	8160.024.010	8161.024.010
8145.300.012	8146.300.012	8330.035.004	8160.033.010	8161.033.010
8145.500.012	8146.500.012	8330.035.004	8160.033.010	8161.033.010
8145.600.012	8146.600.012	8330.035.004	8160.033.010	8161.033.010
8145.300.012	8146.300.012	8330.035.004	8160.033.010	8161.033.010
8145.500.012	8146.500.012	8330.035.004	8160.033.010	8161.033.010
8145.600.012	8146.600.012	8330.035.004	8160.033.010	8161.033.010

Knife 8145/8146/8150/ 8151  
Key 8345.015.000

Knife 8160/8161  
Screw 8315.004  
Key 8345.009

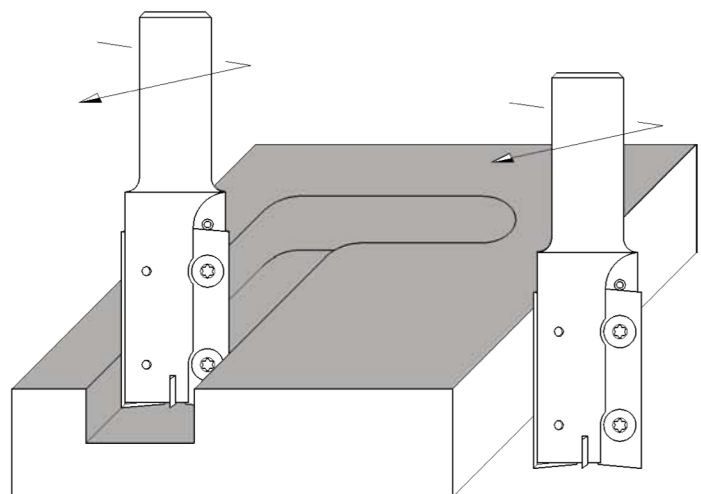
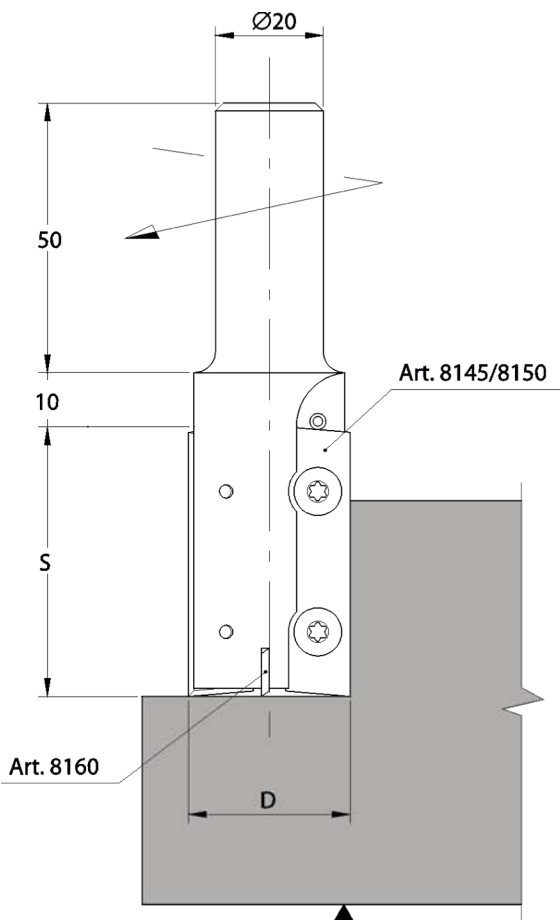





**APPLICATION:**

Sizing of paper, plastic coated, veneered chipboard or MDF/HDF panels.

**MACHINE:**

CNC router.

**TECHNICAL INFORMATION:**

Manufactured with indexable micrograin solid carbide knives. With 2+2 shear up/shear down cutting edges for excellent finishing on top and bottom workpiece surfaces. Cutter body made by "Ergal" light alloy. Supplied with d. 20x50 cylindrical shank.

**MEC HW Z=2+2**

Code	D	S	Rpm Max	Price Code	Profile	Spare Parts			
						Knife	Wedge	Screw	Key
5075.080.036	80	36	14.000	D27	A	8105.200.012	8280.160.000	8285.008.000	8350.040.000
5075.080.056	80	56	14.000	L27	B	8105.300.012	8280.260.000	8285.008.000	8350.040.000

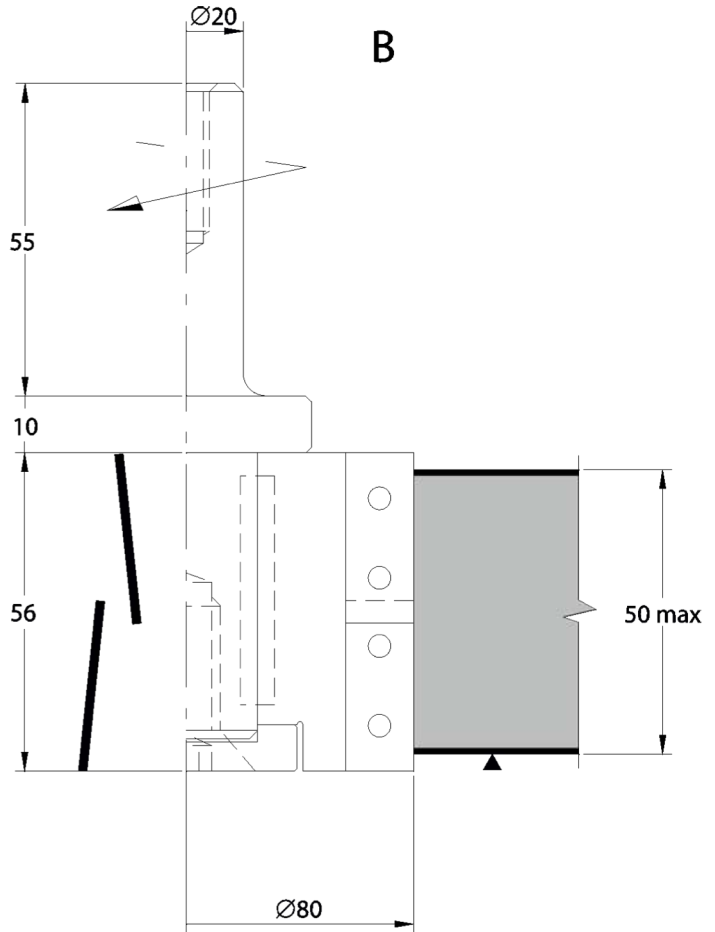
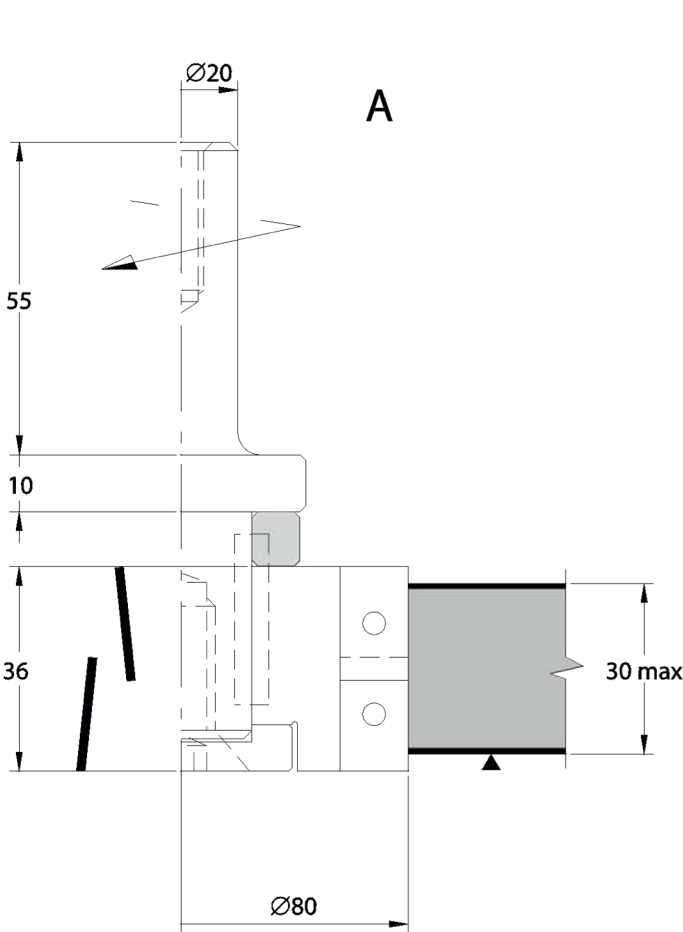



**APPLICATION:**

Sizing of paper, plastic coated, veneered chipboard or MDF/HDF panels with grooving saw blades.

**MACHINE:**

CNC router.

**TECHNICAL INFORMATION:**

Manufactured with indexable micrograin solid carbide knives. With 2+2 shear up/shear down cutting edges for excellent finishing on top and bottom workpiece surfaces. 4 mm TCT Z. 12 saw blade for grooving supplied with the toolset. Cutter body made by "Ergal" light alloy. Supplied with d. 20x50 cylindrical shank.

**MEC HW Z=2+2**

Code	D	D <sub>1</sub>	S	Rpm Max	Price Code	Profile	Spare Parts			
							Knife	Wedge	Screw	Key
5076.080.001	100	80	43	14.000	G29	A	8105.200.012	8280.160.000	8285.008.000	8350.040.000
5076.080.002	100	80	63	14.000	C30	B	8105.300.012	8280.260.000	8285.008.000	8350.040.000

Grooving sawblades see Art. 9140

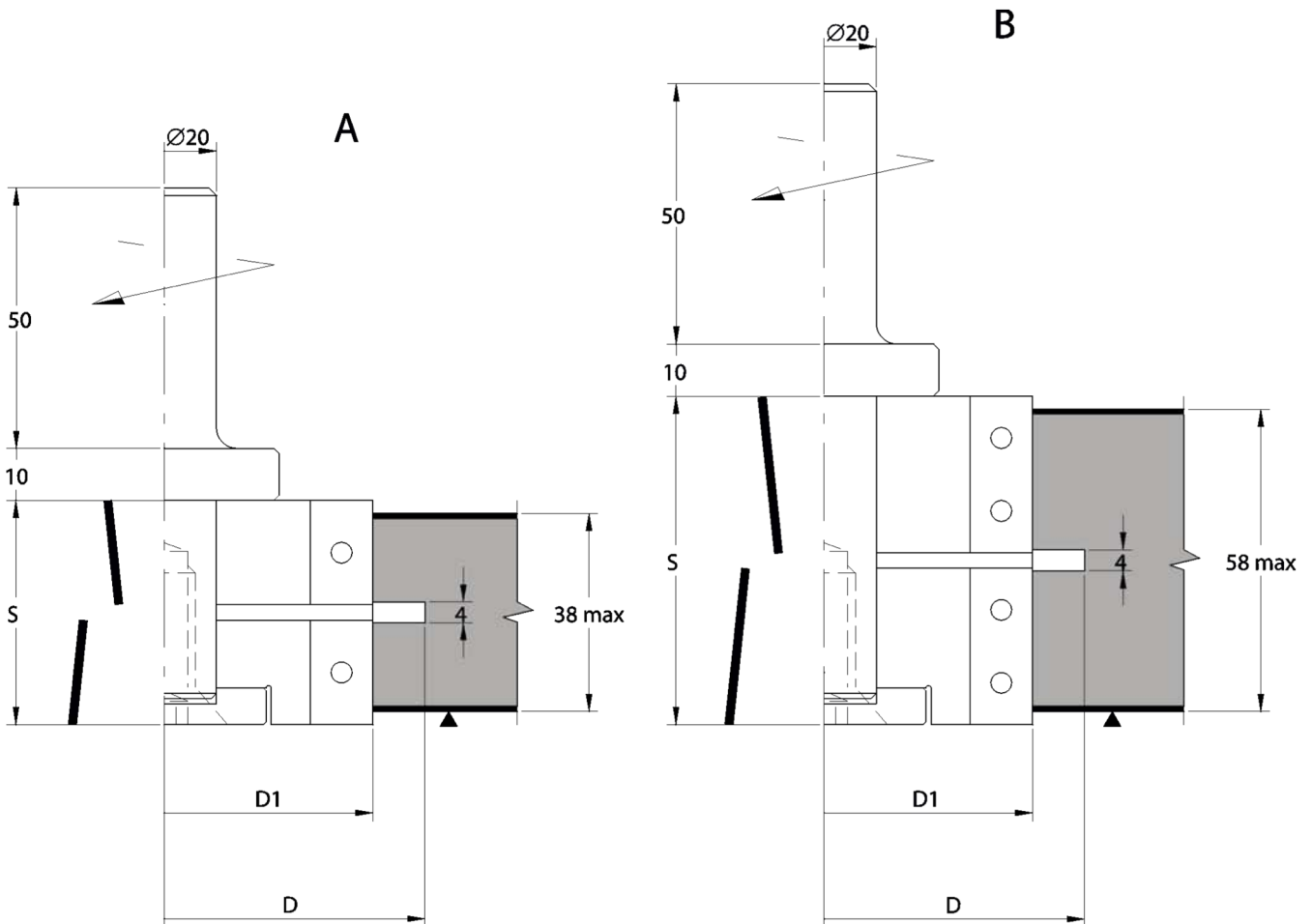



**APPLICATION:**

Panel sizing with plunging capability.

**MACHINE:**

CNC router.

**TECHNICAL INFORMATION:**

Manufactured with indexable micrograin solid carbide knives. The tools has vertical plunging capability. If not specified we will supply the tools with d. 20x40 cylindrical shank and RH rotation. Increase of 15% for tapered shanks.

**MEC HW Z=1**

Code Rh	Code Lh	D	S	Rpm Max	Price Code	Spare Parts			
						Knife Rh	Knife Lh	Screw	Key
5080.012.030	5081.012.030	12	23	24.000	A16	8150.300.009	8151.300.009	8330.035.002	8345.015.000
5080.014.030	5081.014.030	14	23	24.000	C16	8150.300.009	8151.300.009	8330.035.002	8345.015.000
5080.016.030	5081.016.030	16	30	24.000	D16	8145.300.012	8146.300.012	8330.035.004	8345.015.000
5080.016.050	5081.016.050	16	50	20.000	M16	8150.500.009	8151.500.009	8330.035.002	8345.015.000
5080.018.030	5081.018.030	18	30	24.000	H16	8145.300.012	8146.300.012	8330.035.004	8345.015.000
5080.018.050	5081.018.050	18	50	20.000	D17	8145.500.012	8146.500.012	8330.035.004	8345.015.000
5080.020.030	5081.020.030	20	30	24.000	D17	8145.300.012	8146.300.012	8330.035.004	8345.015.000
5080.020.050	5081.020.050	20	50	20.000	L17	8145.500.012	8146.500.012	8330.035.004	8345.015.000
5080.020.060	5081.020.060	20	60	20.000	M18	8145.600.012	8146.600.012	8330.035.004	8345.015.000
5080.022.030	5081.022.030	22	30	24.000	L17	8145.300.012	8146.300.012	8330.035.004	8345.015.000
5080.022.050	5081.022.050	22	50	20.000	E18	8145.500.012	8146.500.012	8330.035.004	8345.015.000
5080.022.060	5081.022.060	22	60	20.000	L19	8145.600.012	8146.600.012	8330.035.004	8345.015.000

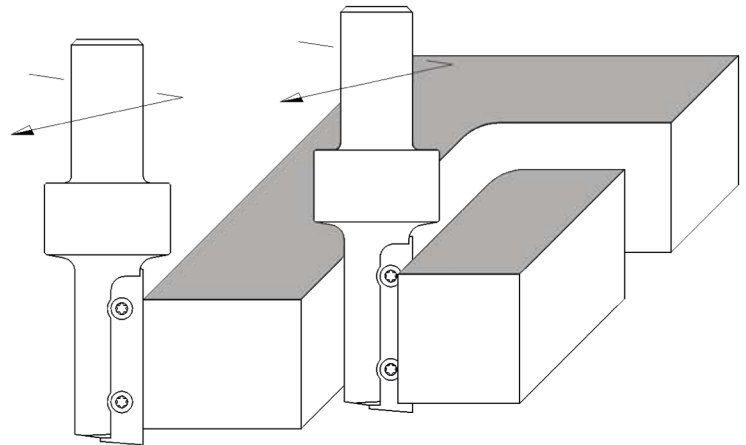
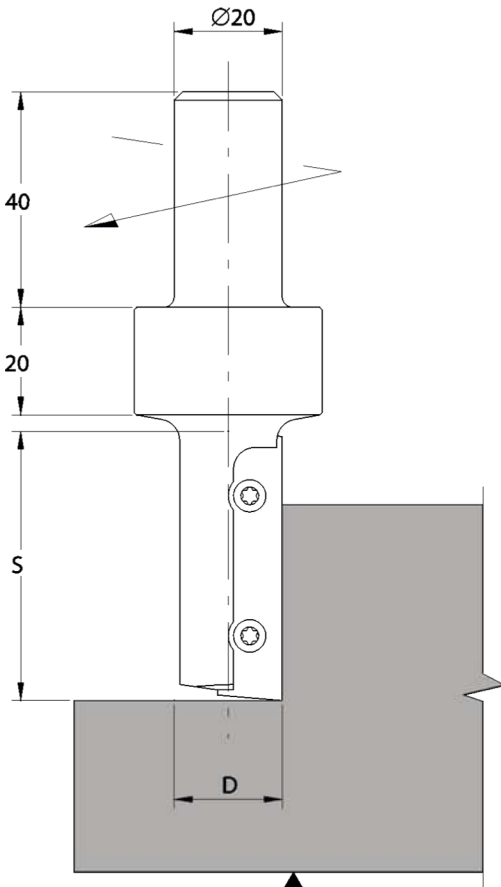



**APPLICATION:**

Sizing of paper, plastic coated, veneered chipboard or MDF/HDF panels.

**MACHINE:**

CNC router.

**TECHNICAL INFORMATION:**

Manufactured with indexable micrograin solid carbide knives. With shear up/shear down cutting edges for excellent finishing on top and bottom workpiece surfaces. Art. 5085 supplied with d. 20x50 cylindrical shank, art. 5086 supplied with d. 25x55 cylindrical shank.

**MEC HW**

**Art 5084 - 5085**

Code Rh	Code Lh	D	S	Z	Rpm Max	Price Code
5085.020.060	5084.020.060	20	58	1+1+1	20.000	C23
5085.020.080	5084.020.080	20	78	1+1+1	20.000	M24

Spare Parts

Knife	Screw	Key
8105.300.012	8330.035.004	8345.015.000
8105.096.012	8330.035.002	8345.015.000
8105.400.012	8330.035.004	8345.015.000
8105.096.012	8330.035.002	8345.015.000

**Art 5086 - 5087**

Code Rh	Code Lh	D	S	Z	Rpm Max	Price Code
5086.030.080	5087.030.080	30	75	2+2+2	20.000	M26

Spare Parts

Knife Rh	Knife Rh	Screw	Key
8150.400.009	8151.400.009	8330.035.002	8345.015.000
8105.076.012	8105.076.012	8330.035.002	8345.015.000

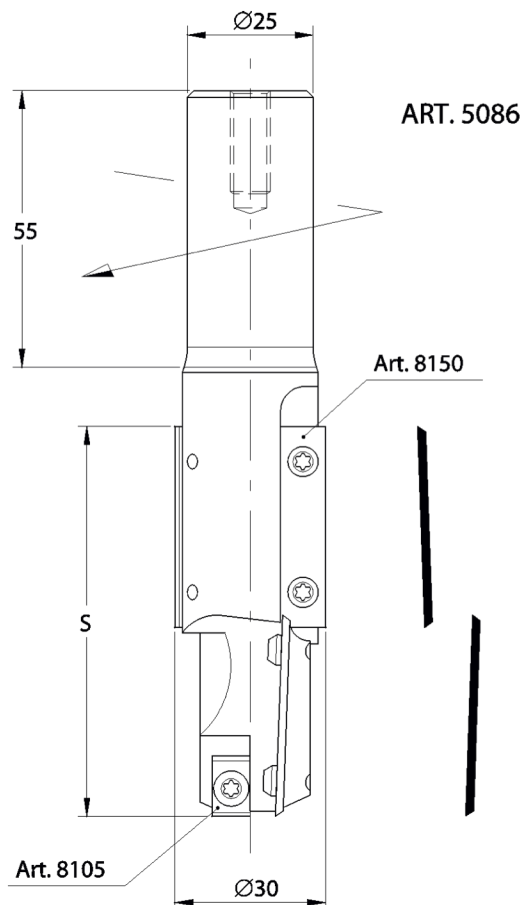
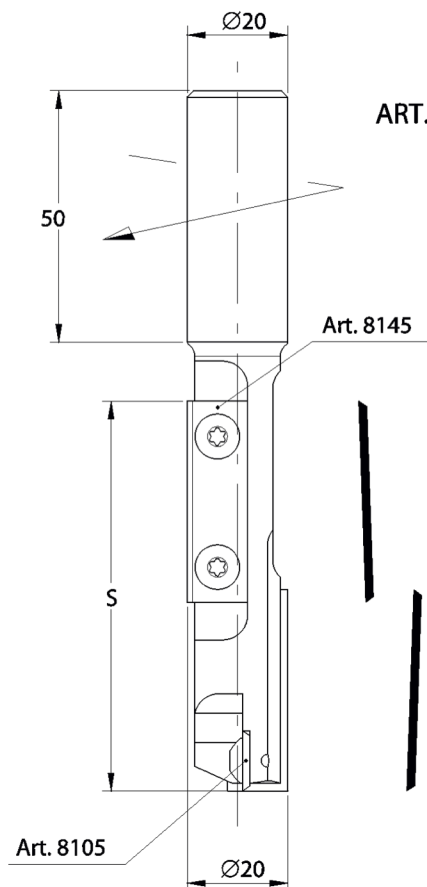



**APPLICATION:**

Panel sizing with high performance roughing cut.

**MACHINE:**

CNC router.

**TECHNICAL INFORMATION:**

Manufactured with indexable micrograin solid carbide knives. High performance roughing cut thanks to the multicut design of the tool. Supplied with cylindrical shank d. 20x50 up to D. 35, and with cylindrical shank d. 25x55 for cutter D. 60.

**MEC HW**

Code	D	S	Z	Rpm Max	Price Code	Spare Parts		
						Knife	Screw	Key
5095.020.062	20	62	2/6	20.000	H23	8105.120.012	8330.035.004	8345.015.000
5095.026.052	26	52	2/6	20.000	M23	8105.105.012	8330.035.002	8345.015.000
5095.035.062	35	62	3/9	18.000	D24	8105.120.012	8330.035.004	8345.015.000
5095.060.080	60	80	4/16	16.000	L25	8105.120.012	8330.035.004	8345.015.000

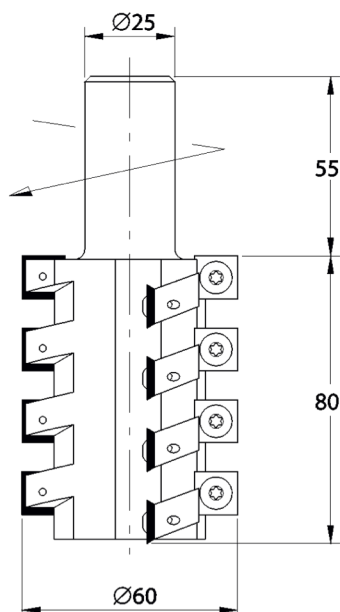
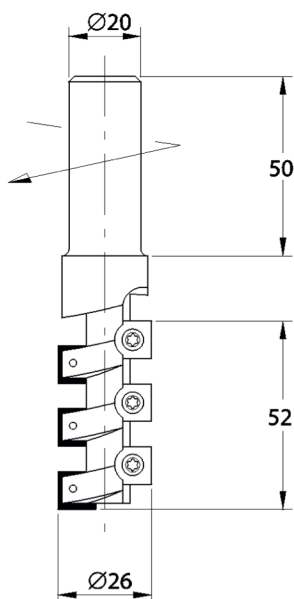
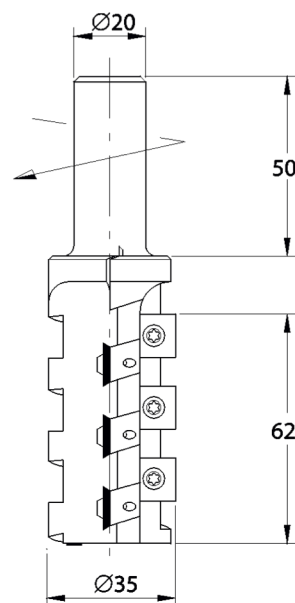
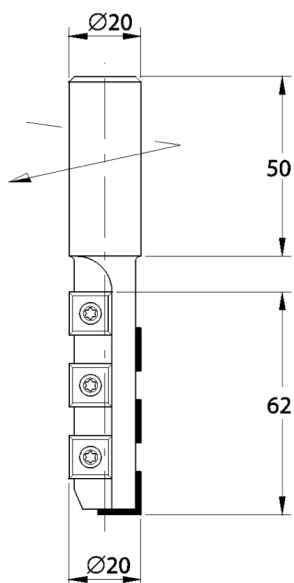



**BUP**<sup>®</sup>  
U T E N S I L I



**BUP Utensili**

61122 Pesaro • Italy • Via Liguria, 15  
Tel. (39)0721\_453454 (4 linee r.a.)  
Fax (39)0721\_455448  
[www.buputensili.it](http://www.buputensili.it) • [info@buputensili.it](mailto:info@buputensili.it)



**CP Tooling and Machinery Ltd**  
16 Harelands Court Yard Offices  
Moor Road  
Melsonby  
Richmond  
DL10 5NY

Tel. 01748 897170  
[info@cptooling.co.uk](mailto:info@cptooling.co.uk) - [www.cptooling.co.uk](http://www.cptooling.co.uk)